

INTRO | mki x es(edu)

Hey there, thanks for buying **KONSTRUKT-8**! It's a full analog drum machine consisting of 8 individual modules that we have developed to teach people with little to no prior experience how to design analog synthesizer circuits from scratch. So what you'll find in the box is not simply meant to be soldered together and then disappear in your rack.

Instead, we want to take you through the circuit design process step by step, explaining every choice we've made and how it impacts the finished module. Each module has its own build guide, and we recommend working through them in this order: Kick, Snare, Output Mixer 2, Hi-Hat, Compressor, FM Drum, BBD, Drum Sequencer. This way, things start relatively simple and get more complex as you go.

For each guide, we strongly suggest you follow along using **LABOR**, which is an all-in-one circuit prototyping tool that allows you to experiment and play around with your components in a non-permanent way. To help you with this, we've included suggested breadboard layouts in select chapters. You can also use a standard breadboard, but this will require you to do some additional engineering to get the different supply voltages.

In addition to this, you can also play around with most of the chapter's circuits in a circuit simulator called CircuitJS. CircuitJS runs in your browser. You'll find weblinks in the footnotes which will direct you to an instance that already has example circuits set up for you. We strongly encourage you to fiddle with the component values and general structure of those circuits to get a better understanding of the concepts we're laying out.

Since this is the first build guide in the series, we've included a components & concepts appendix that covers circuit design foundations – things like what resistors and capacitors actually do, how voltage, current, and resistance interact, and so on. If you're new to electronics, don't hesitate to check in there whenever you feel like you're missing an important piece of information. Later build guides won't repeat this material, so it's a good reference to keep handy. Most importantly though: have fun!

TABLE OF CONTENTS

CIRCUIT SCHEMATIC	2
BILL OF MATERIALS	3
POWERING YOUR BREADBOARD	6
USAGE WITH MKI x ES LABOR	7
CIRCUIT DESIGN CLOSE-UP	9
COMPONENTS & CONCEPTS APPENDIX	35
TOOLS APPENDIX	47
MODULE ASSEMBLY APPENDIX	49
TROUBLESHOOTING APPENDIX	59

BILL OF MATERIALS

Before we start, please check if your kit contains all of the necessary components. In addition to a PCB, panel and power cable, your box should also contain:

An array of resistors. The specific values (in ohms, which you should check for with a multimeter) are

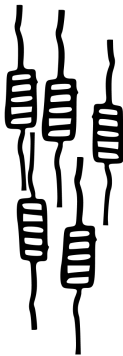

1M	x2
470k	x1
120k	x1
100k	x5
47k	x2
39k	x1
33k	x2
14k	x1
10k	x2
2k	x1
1k	x3
10Ω	x2

A bunch of capacitors. The specific values (which are printed onto their bodies) are

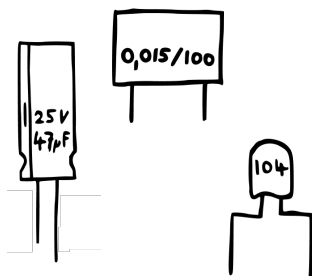

47µF (electrolytic)	x2
220nF (foil)	x1
100nF (ceramic)	x6
15nF (foil)	x3
10nF (foil)	x1
3n3 (foil)	x1

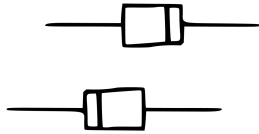

Some diodes. The specific model names (which are printed onto their bodies) are

1N4148 (signal) x7

1N5819 (schottky) x2

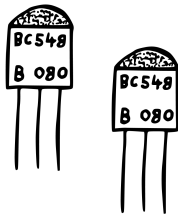

A couple of transistors. The specific model names (which are printed onto their bodies) are

BC558 (PNP) x2

BC548/547 (NPN) x3

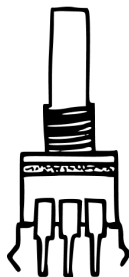

A handful of potentiometers. Their specific values (which may be encoded & printed onto their bodies) are

1M (B105) x1

250k (B254) x1

100k (B104) x2

100k (A104) x1

50k (B503) x1

10k (B103) x1

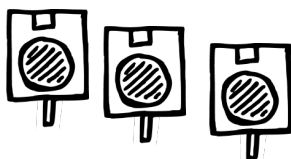

A few jack sockets. The specific models (which you can identify by their color) are

Switched mono (black) x4

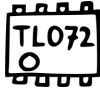

A couple chips. Their specific models (which are printed onto their bodies) are

TL072 (dual op amp) x2

You will also find a few sockets that are only relevant when assembling the module in the end.

POWERING YOUR BREADBOARD

Before we can start building, you'll need to find a way of providing your breadboard with power. Ideally, you'd use a dual 12 V power supply for this. Dual power supplies are great – and if you want to get serious about synth design, you should invest in one at some point. But what if you're just starting out, and you'd like to use batteries instead? Thankfully, that's totally doable. **You just need to connect two 9 V batteries to your breadboard like shown here.**¹ For this, you should use 9 V battery clips, which are cheap & widely available in every electronics shop.

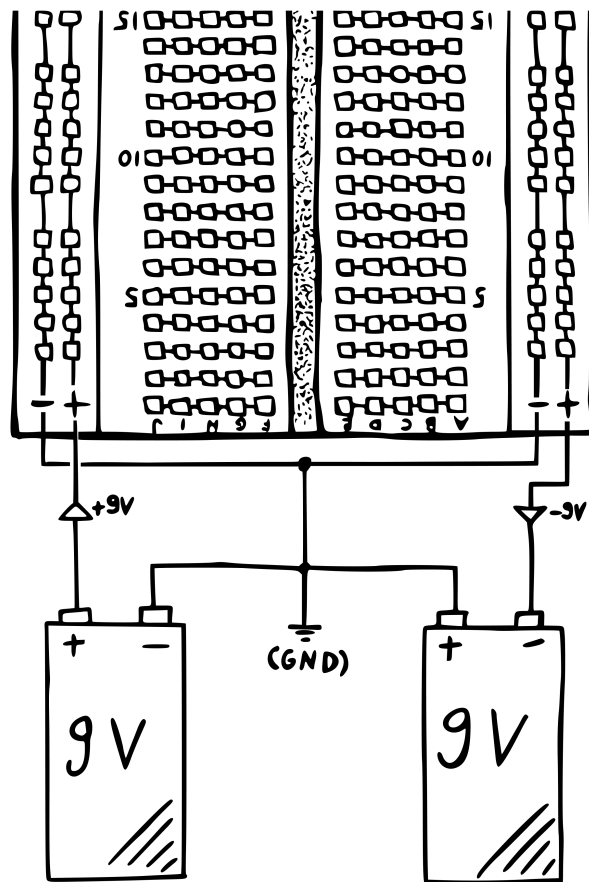

By connecting the batteries like this, the row on the left side labeled + becomes your positive rail, the row on the right side labeled + becomes your negative rail, and both rows labeled – become your ground rails.²

Please make sure you disconnect the batteries from your breadboard when you make changes to the circuit! Otherwise you run the risk of damaging components.

¹ Since the circuits in this manual were designed for a 12 V power supply, we assume that to be the default. Everything will still work roughly the same with 9 V, though.

² This is a bit awkward because breadboards weren't really made with dual supply voltages in mind.

USAGE WITH MKI x ES LABOR

Alternatively, you can follow this guide using an **MKI x ES LABOR** prototyping board. LABOR comes equipped with everything you need for testing the circuits we lay out: a standard 830 tie point breadboard, an integrated dual power supply with over current protection, a manual gate/trigger/envelope generator, an LFO, a variable CV source, an output amplifier, and a modular interfacing section where you can insert all of your interfacing components like potentiometers, jack sockets, and switches.

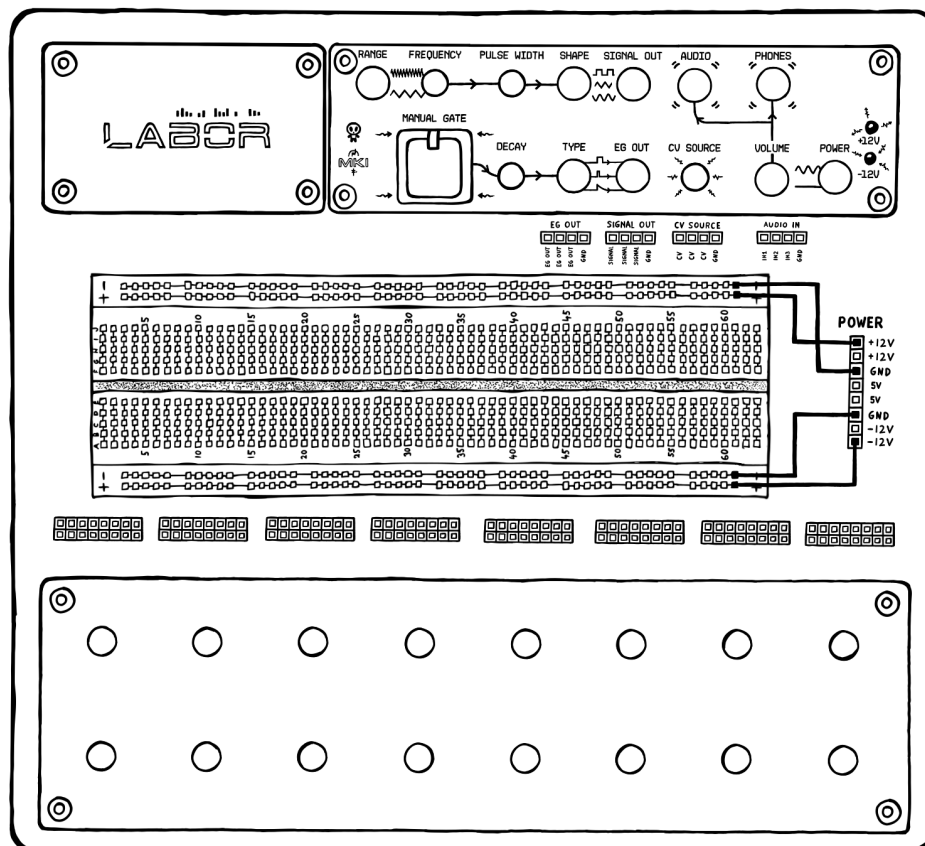

Before you get started, connect the slots labeled **GND** on the power header to both breadboard rails labeled - (minus). Next, connect one slot labeled **+12 V** to the top breadboard rail labeled + (plus), and one slot labeled **-12 V** to the bottom breadboard rail labeled + (plus). This way, the power rails match the setup of the suggested breadboard layouts in this manual.

Speaking of those suggested breadboard layouts: you'll notice that they prompt you to insert your interfacing elements directly into the breadboard, which can be finicky. When using LABOR, you don't have to deal with this. Instead, plug those interfacing elements into the modular interfacing section at the bottom and connect them to the breadboard in the designated spots via the interfacing headers. You can read more about how this works in the LABOR user manual.

To listen to your circuit, you don't even need to set up an output jack socket. Instead, use the built-in output amplifier at the top of the device. Just plug your circuit's signal output into the header labeled **AUDIO IN**, and then connect your headphones to the **PHONES** output jack (or a line-level device like a standalone external speaker to the **AUDIO** output jack).

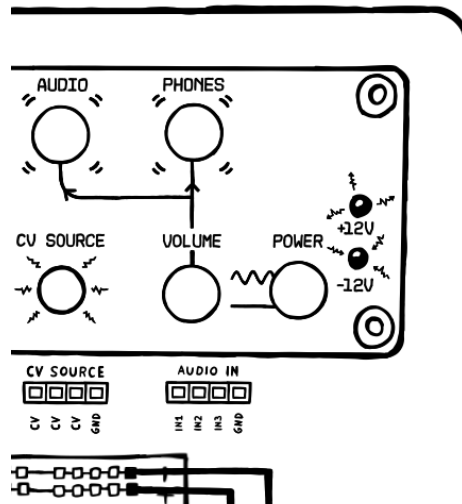

Sometimes, this guide will ask you to use external gear like sequencers or LFOs to send CV, audio signals, triggers or gates into your circuit. With LABOR, there's no need for extra equipment – just use the built-in oscillator (audio/LFO), CV source or manual gate/envelope generator. You can grab all of those via the headers labeled **EG OUT**, **SIGNAL OUT**, and **CV SOURCE** and connect them to the designated points on the breadboard.

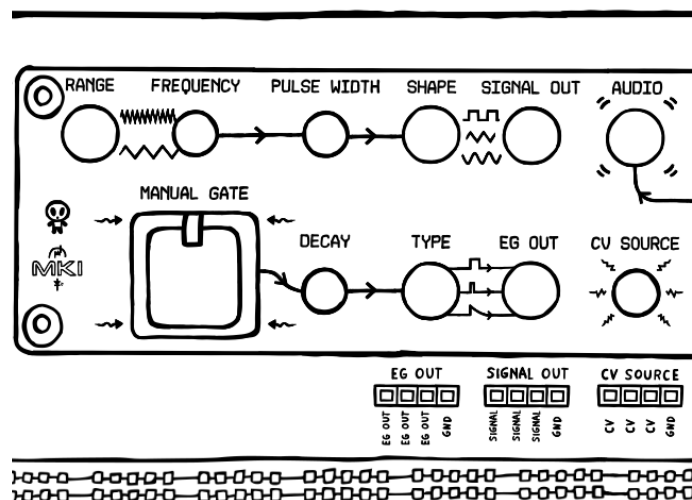

KICK DRUM BASICS

To make our lives a little easier, let's start by broadly thinking about the functional blocks we'll need for a synthesized kick drum. First up: some sort of oscillator. This is a no-brainer, since we have to have a sound source to work with.



A typical oscillator will give us a static waveform like a sawtooth, square, triangle or sine that just keeps going indefinitely. Since a kick drum is percussive in nature though, we will have to somehow shape that waveform's volume curve into a quick burst.



Of course we don't want this to happen just once – but every time we trigger our circuit with a gate signal coming from a sequencer or an LFO. Also, we'll probably want to emulate the initial punch that you'd expect from a real drum. Traditionally, you'd do that by manipulating the pitch alongside the volume, starting off quite high, and then very quickly dropping towards a steady base frequency.

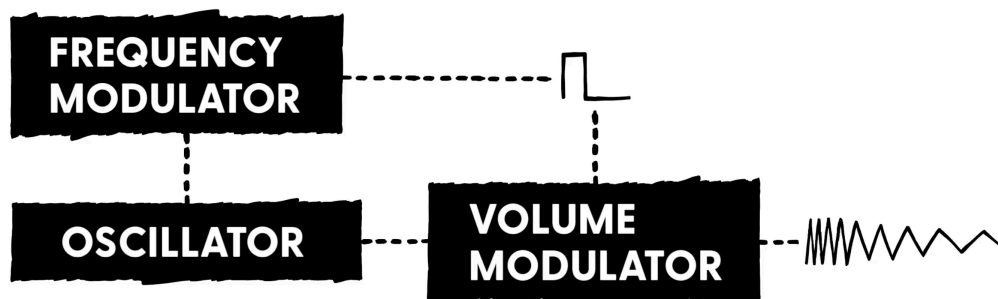

Alright, this should be everything we need. So let's think about how we could implement these blocks in our circuit. In an ideal scenario, we'd want to use a full blown VCO as our oscillator, so we can precisely manipulate its pitch via a control voltage coming from an envelope generator.

Next, we'd need to add a proper VCA and yet another envelope generator, which, in combination, would allow us to shape the signal's volume curve into the aforementioned quick burst. Now, the problem with this approach is that each of these circuits is plenty

BRIDGED-T OSCILLATOR

Basically, they found a way to smash a pseudo-VCO, VCA and envelope generator into a single block made from just a handful of components. The basis for that block is this little circuit consisting of just one op amp, two resistors and two capacitors. **Together, they form a strange sine wave oscillator that needs to be kickstarted by a voltage pulse to actually oscillate.** And even then, it won't continue oscillating (like other oscillators do), but quickly drop in volume and eventually die out completely. Which isn't great for most scenarios – but ideal for ours!

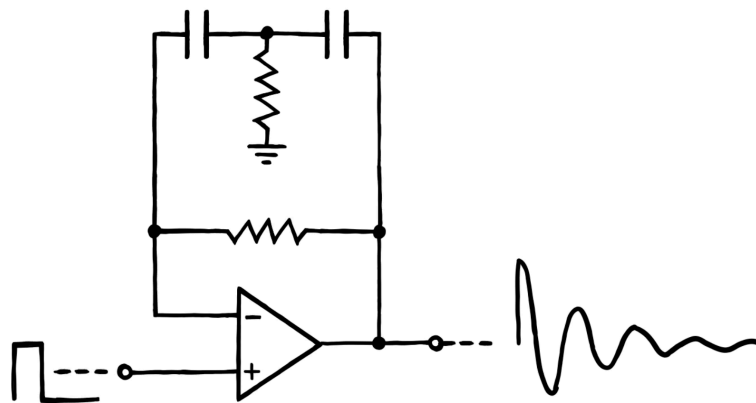

So let's look at how this works.³ We'll assume that the voltage at the op amp's non-inverting input quickly jumps from 0 to 1 V. Now, to reach a state of balance, the op amp will try to push the voltage at its inverting input up to 1 V as well. For that, it'll increase its output voltage to 1 V. Initially, this will work just fine, since that voltage pushes straight through the two capacitors and reaches the inverting input that way.

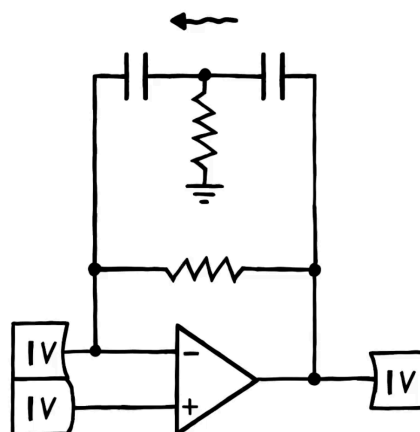

³ You can try this chapter's circuit in a simulator. I've already set it up for you [right here](#). You can change all values by double clicking on components.

But because there is a resistor to ground between the two caps, we'll see current drain out from the first capacitor. Which means that the voltage applied to the second cap (and subsequently, the inverting input) will drop. To compensate, the op amp will raise its output voltage. **But as it does that, even more current is squeezed out of the first cap, forcing the op amp to push even harder.**

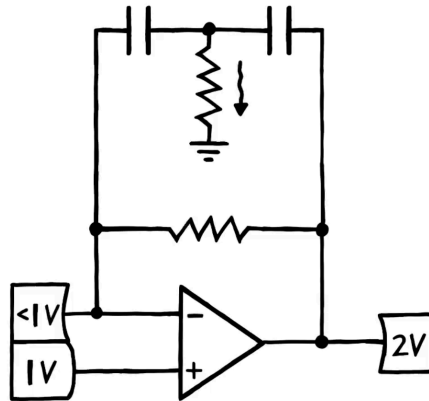

And this would continue until the op amp runs into the upper supply voltage – if it weren't for the bridge resistor between output and inverting input. **Because as the op amp pushes harder and harder, that resistor allows a small current to charge up the second cap from the other side.**

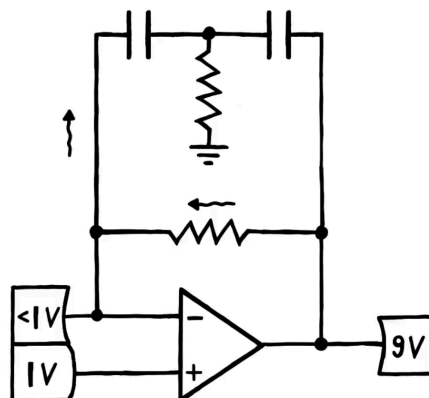

At some point, this process will add more voltage on the left as we lose on the right, causing the whole mechanism to kick into reverse gear. Now, the op amp will start dropping its output voltage to try and course correct. Only problem is that this will pull current out of the first cap, and subsequently up from ground, increasing the voltage between the two caps and also at the inverting input. Which forces the op amp to reduce its output voltage even further.

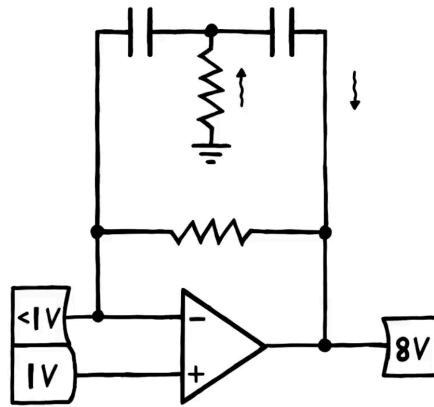

Eventually, we'll again reach a tipping point where the whole mechanism reverses. Only this time, it'll be at a slightly lower output voltage. **That's because with every charging and discharging cycle, we lose a bit of the momentum we initially put in.** The circuit behaves kinda like a pendulum that way.

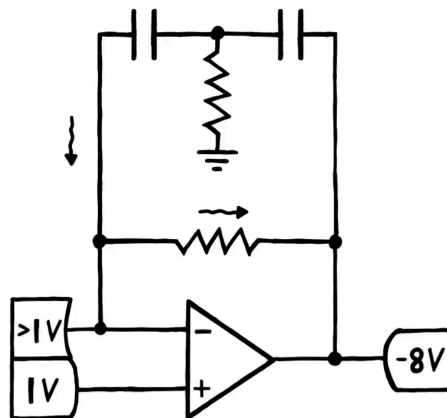

And so the output it produces is a sine wave swinging around the non-inverting input voltage with a steadily decreasing amplitude. Which should already sound pretty kick drum-ish – if the frequency is low enough. To make sure that it is, we have to choose the right combination of capacitor and resistor values. **This is a little tricky, since all of those values influence both frequency and decay at the same time.**

In the original 808 bass drum schematic, Roland use a 1M bridge, a $\sim 51k$ resistance to ground and two 15nF capacitors, giving them a 50 Hz oscillation frequency with a quick, but still discernible decay. Let's use those values as a starting point.

To be able to actually trigger the sound, we'll then add a quick and dirty gate input. Because the oscillator needs enough room to swing, we'll have to divide the gate voltage down. For that, we'll simply insert a 100k/14k voltage divider at the non-inverting input.

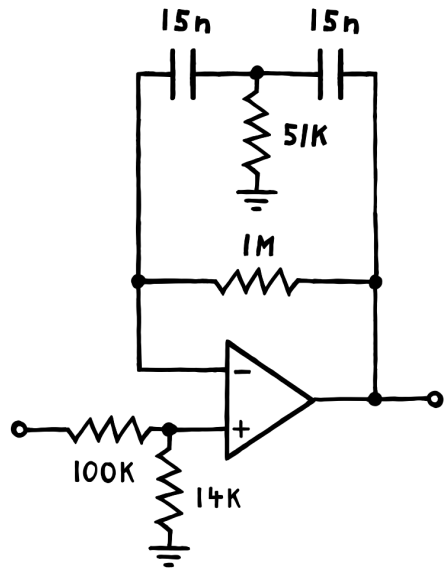

To test this out, I recommend that you set the circuit up on a breadboard and then connect an LFO, sequencer or similar to the gate input.⁴ You can listen to the output using any kind of headphones.

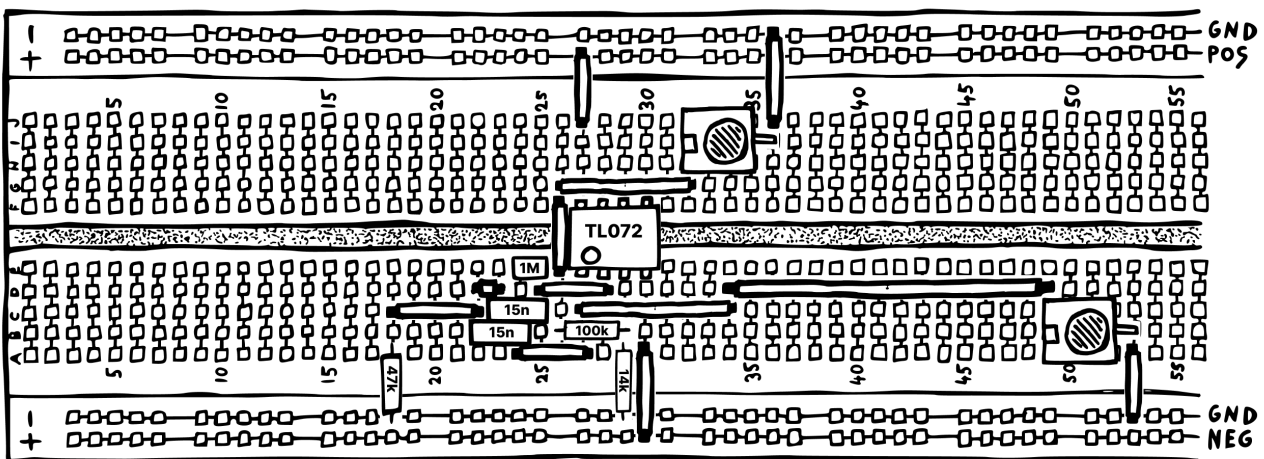

You should get a quick, low-frequency bump when the gate goes high. Great! Though you might also notice a second bump when the gate goes low. What's up with that? Well, as we saw earlier, the oscillation is triggered when the voltage at the non-inverting input changes and the op amp struggles to charge (or discharge) the second cap to that voltage. So it makes sense that we get a second bump when the input voltage drops.

⁴ Note that I had to switch the 51k resistance to ground with a 47k, since your kit does not contain a 51k resistor.

GATE-TO-TRIGGER CONVERTER

How do we fix this? **Simple: we'll shorten the gate so much that the two separate kick hits blend into one and the same.** For that, we'll set up a little circuit known as a gate-to-trigger converter. It consists of two distinct sections. First, a high pass filter with a pretty steep cutoff frequency. And second, an op amp-based comparator. Here's how it works.⁵

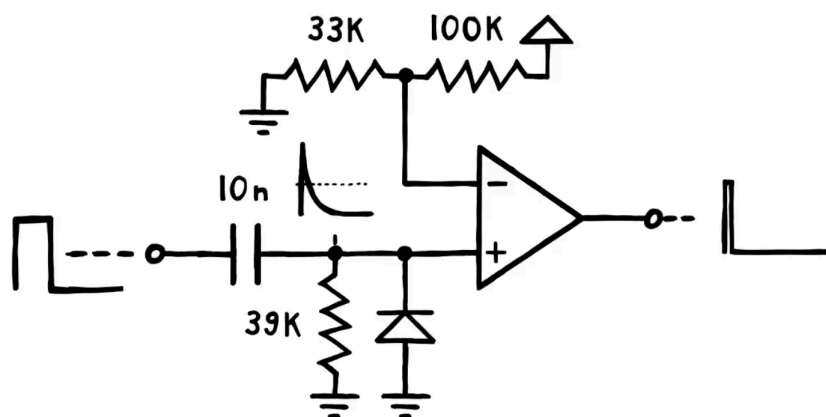

When we apply a gate signal to the input capacitor, we get a voltage spike on the other side that quickly dies down as the cap charges through the 39k resistor to ground. **For the split second this spike crosses its threshold voltage, the comparator will then push out an extremely short 12 V gate – also called a trigger.** (Those 12 V are then scaled down to around 1.4 V by the voltage divider at our kick's trigger input.)

You'll notice that there's also a diode pointing up from ground at the op amp's non-inverting input. This is necessary because some op amps will glitch out if they read a very negative input voltage in this scenario. This is an issue because once the gate goes low, we'd normally see a big negative spike as the capacitor discharges. The diode mitigates that by allowing the cap to discharge instantly.

Great! There's just one more issue left to solve with this setup. During the comparator's low state, it'll set its output to -12 V – simply because that's what we give it as its low supply voltage. This is not ideal. Because remember: our oscillator will swing around the voltage we apply to the non-inverting input. For audio signals, that voltage should be 0 V. So how do we fix this? **Simple: by putting a diode between the gate-to-trigger converter and the kick's trigger input.** This way, the trigger can pass through, but the comparator's low state is blocked – and the voltage gets pinned to ground level via the voltage divider instead.

⁵ You can try this chapter's circuit in a simulator. I've already set it up for you [right here](#). You can change all values by double clicking on components.

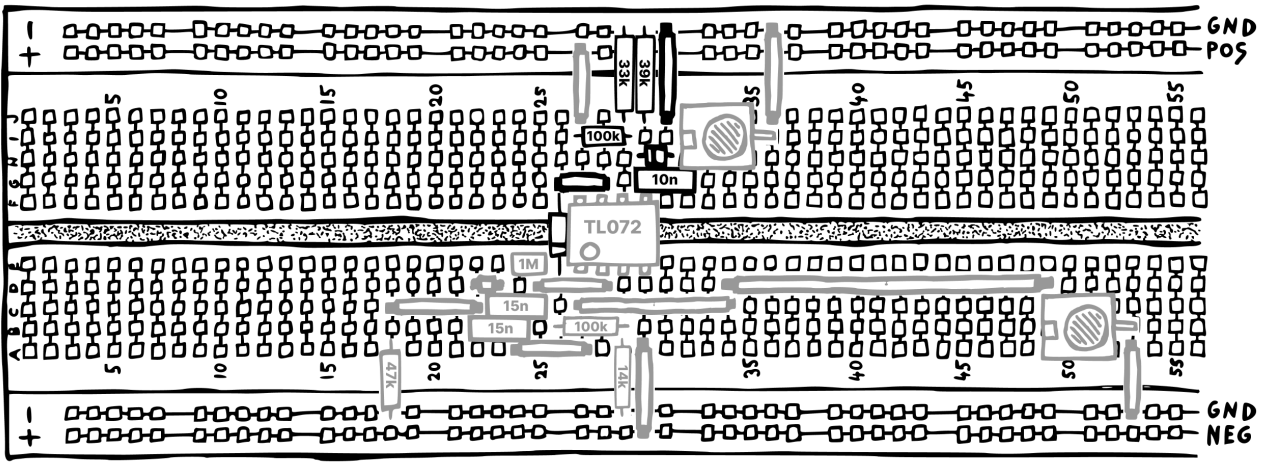

If you now feed your gate signal into the gate-to-trigger converter, you should get a single kick hit instead of two per gate.

VARIABLE KICK PITCH

Next, let's try and mess with the oscillator's pitch. As I mentioned before, this is a little tricky, since all of the component values in the feedback path influence both pitch and decay at the same time. **That said, varying the resistance to ground is probably our best bet, since it affects the pitch much more noticeably than the decay.** So we'll replace the 51k resistor with a 250k potentiometer.

This by itself would allow us to vary the pitch over a pretty wide range. Now, for our kick drum, it makes sense to restrict that range to the lower frequency spectrum. To do that, we just have to put a baseline resistance in series with our potentiometer. **With a 10k, the highest possible pitch is around 110 Hz, which is bordering on tom territory.**⁶

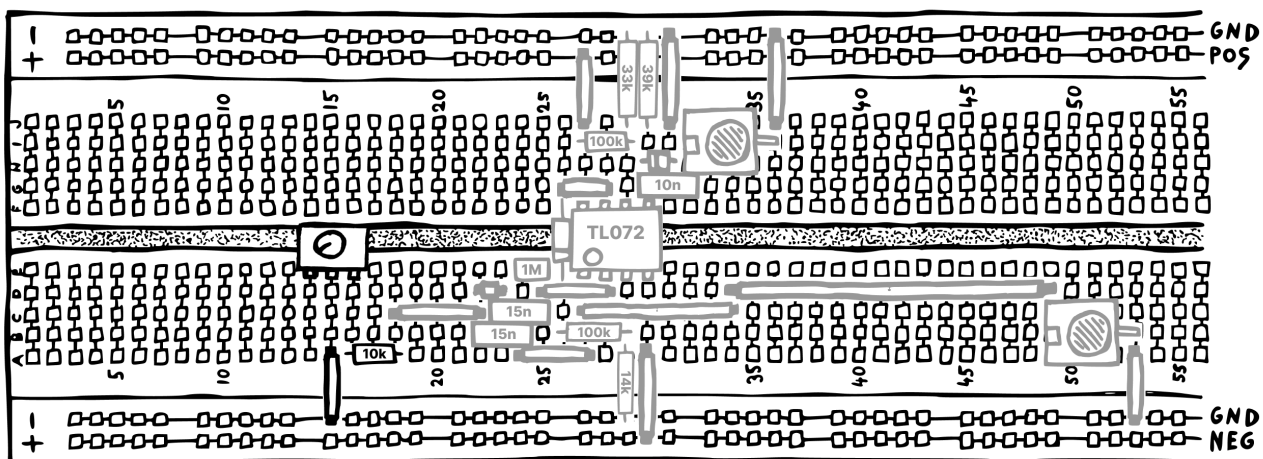
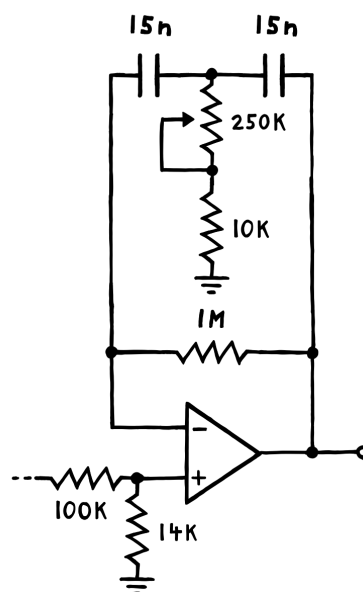

By playing with the potentiometer, you should now be able to set the base pitch. Great!

⁶ You can try this chapter's circuit in a simulator. I've already set it up for you [right here](#). You can change all values by double clicking on components. Also, note that you can adjust the pitch range to your liking by changing the baseline resistance and potentiometer value.

VARIABLE DECAY

With the pitch sorted, let's talk about the decay. Right now, it's a little quick for my taste, so I'd like to make it a good deal longer. Unfortunately, this will be a bit more involved than changing the pitch. **That's because in order to keep the oscillation going for longer, we either need to reduce the amount of momentum we lose during each wavecycle – or find a way to add some back in.**

To try and do the former, we'd need to increase the value of the bridge resistor. Because as a rule of thumb, the relation between bridge and resistance to ground determines how much momentum we lose per wavecycle. If they're close to the same value, you won't get any oscillation. If they're orders of magnitude apart, you get a decently long tail.

Only trouble is that a) increasing the bridge resistance will also lower the pitch and b) there's a hard upper limit for the maximum decay we can squeeze out of this. **Since we're already pretty close to that upper limit (and it'd be great if the pitch stayed the same), I think we should skip this approach and focus on the other one: adding momentum back in.** To do that, we'll set up an inverting buffer and feed it the kick's output. Then, we'll take the buffer's output and connect it to the node between our two capacitors through a big resistor.⁷

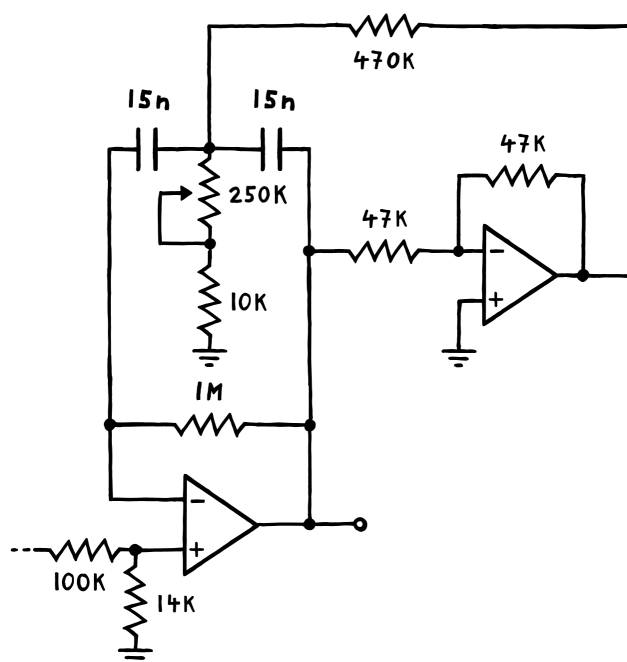

Here's how it works. We'll imagine that we've just triggered the kick, which means that the output voltage is rising. Like before, this will push current out of the first capacitor. But unlike before, we also actively pull current out via this newly added, second path. That's

⁷ You can try this chapter's circuits in a simulator. I've already set them up for you [right here](#). You can change all values by double clicking on components.

because the inverting buffer's output voltage will always be the inverse of the kick's output voltage.

So as the voltage pushing against the first cap increases, the voltage pulling at it from the other side decreases in lockstep. Which, in turn, decreases the voltage at the inverting input, forcing the kick to push even harder.

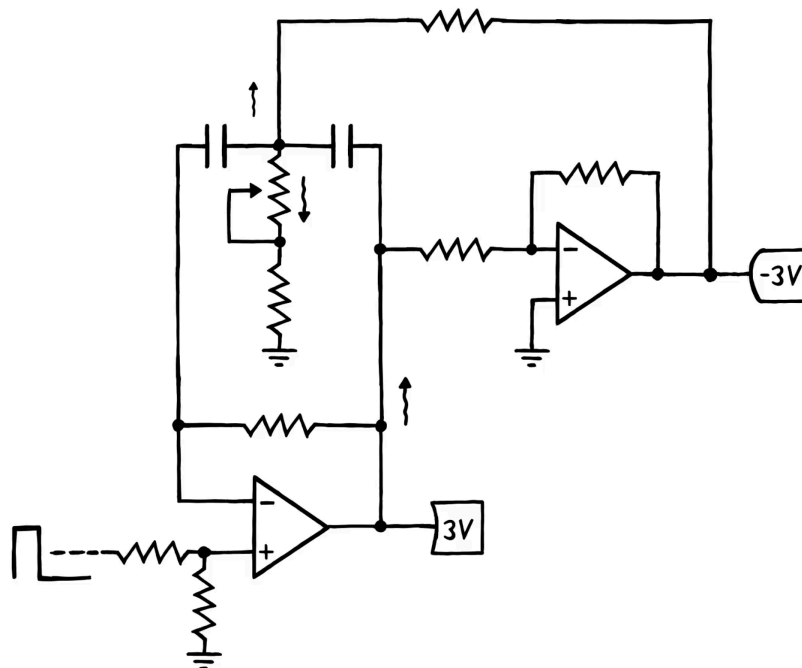

And of course, the same idea applies in reverse when the kick's output drops below 0 V. Then, the inverting buffer will push against the caps, exaggerating the downward motion of the kick. **We're basically applying positive feedback to the system.** Which, with the resistor values specified above, will keep the oscillation going indefinitely without altering the pitch.

Since we do want that oscillation to die down over time though, we'll need to dial back the amount of feedback we apply. For that, we'll simply add a control that allows us to reduce the inverting buffer's gain. That gain, in case you don't know, is set by the relation between the input and the feedback resistance.

If the feedback resistance is smaller than the input resistance, the gain drops below 1 (and vice versa). So we could simply replace that feedback resistance with a potentiometer. **Unfortunately, there is a small issue with this idea: the relation between the inverting buffer's gain and the amount of decay we get is exponential.** So as we'd change the resistance linearly, the decay would change exponentially.

To counteract this, we could switch our linear pot for a reverse logarithmic one, which would cancel out the exponential behavior. Unfortunately, that type of pot can be difficult to find. **Lucky for us, we can fake a reverse log potentiometer if we simply put a big linear pot in parallel with the original 47k resistor.** Because of the way those resistances will interact, the end result mimics a reverse log curve quite convincingly.

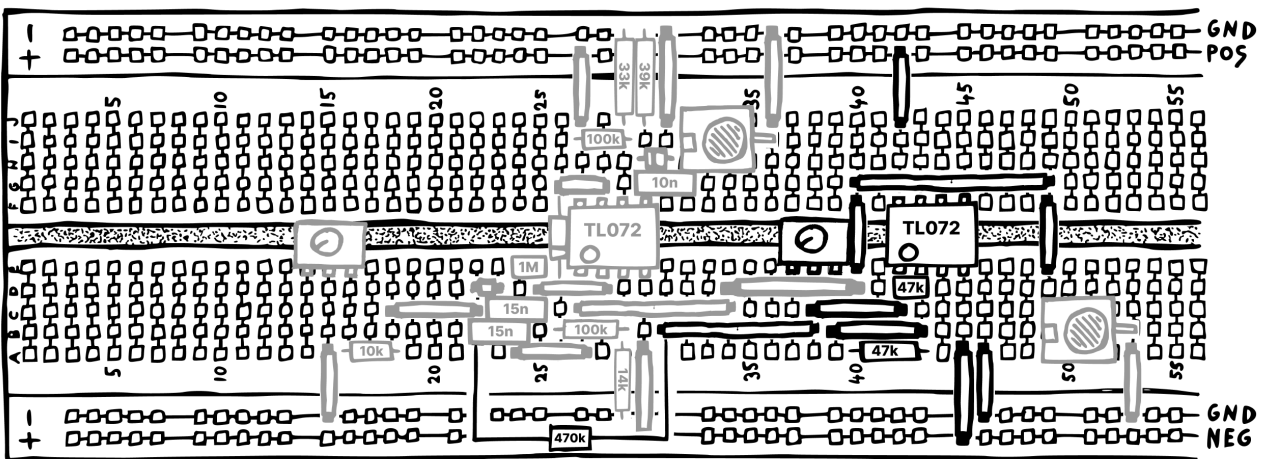
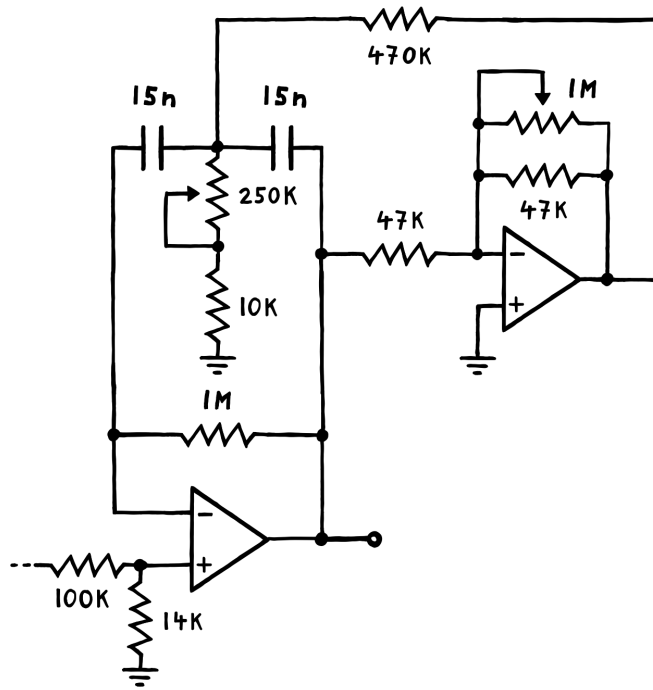

If you test this, you'll notice that dialing in the decay goes from short to long very smoothly. What's even better is that the kick doesn't go into full drone mode at the maximum setting. That's because two resistances in parallel will always net you a lower total resistance than either individually.

BASIC PITCH CV

Alright, so that's the decay down. Our kick is starting to take shape, but there's one essential element still missing: the initial punch you get from a pitch envelope. **To get there, we need to modify our design so that the kick's pitch can be manipulated using a voltage.** But doing this cleanly would be quite involved.

Thankfully, there's another quick and dirty hack we can apply here. Remember how we discovered that the resistance to ground between the two capacitors determines the oscillation frequency? That was because the faster current can be pushed out of or pulled into the first capacitor, the faster the whole mechanism will swing. So if we had a component whose resistance can be controlled with a voltage, we'd be golden.

Unfortunately, that component doesn't really exist – at least not in an ideal form. So we'll have to make do with a compromised version. **And the most widely available compromised version is probably the good old NPN transistor.** On paper, it sounds like it does exactly what we're looking for: allowing more or less current to flow between its collector and emitter in response to a voltage we apply to the base. In practice, there are of course a ton of caveats to this (which we'll run into in a second).

Still, it's worth a shot – so let's try and add an NPN transistor going to ground in parallel with our existing resistance. **This way, we get the pitch we dial in using the potentiometer if the transistor is completely closed – and we assume that we can increase it from there by applying a voltage to the transistor's base, opening it up.**

We shouldn't do that directly though, because the path between base and emitter basically turns into a short circuit if the base voltage increases past 600-700 mV. So we'll add a 100k series resistor to protect our transistor.⁸

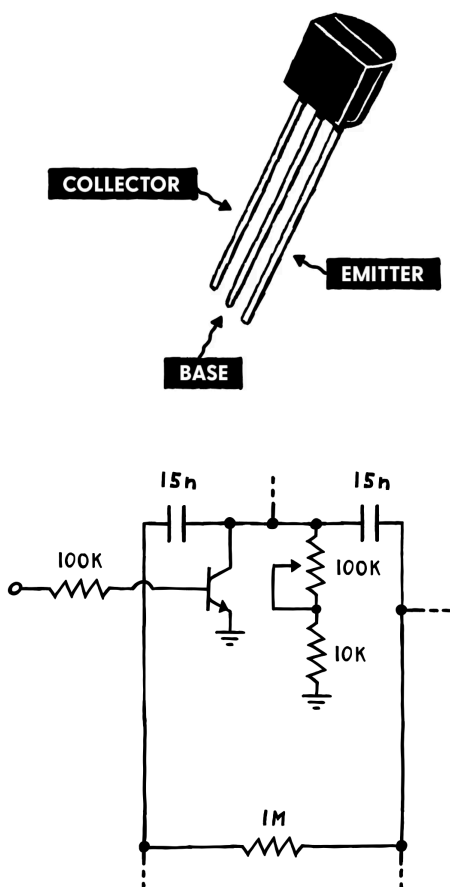

⁸ You can try this chapter's circuit in a simulator. I've already set it up for you [right here](#). You can change all values by double clicking on components.

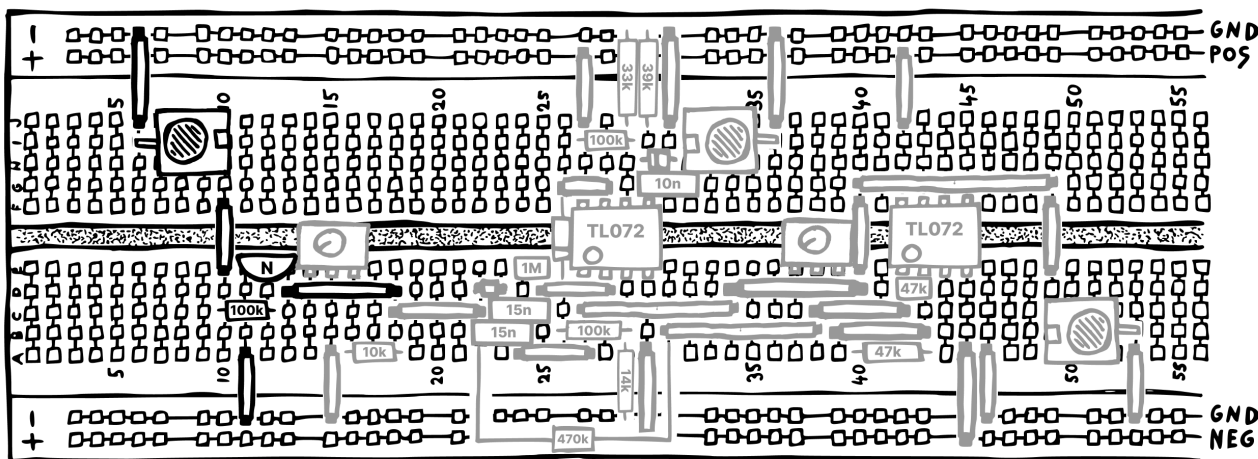

To try this out, connect your sequencer's CV output to the newly added input socket. By dialing in different CV levels per step, you should be able to manipulate the kick's pitch. Great, so that does indeed work! But what about the caveats I mentioned? Does this mean you can plug in NPN transistors anywhere you need a voltage controlled resistance?

Let's take a closer look at the actual waveform our oscillator now produces. For that, you'll need to monitor the output using an oscilloscope. When you do this, you'll notice that the clean sine wave we get without CV morphs into something like a rounded sawtooth. What's up with that? **Well, we're running into one of the major caveats of using an NPN transistor as a makeshift voltage controlled resistor: asymmetry.** Here's what I mean.

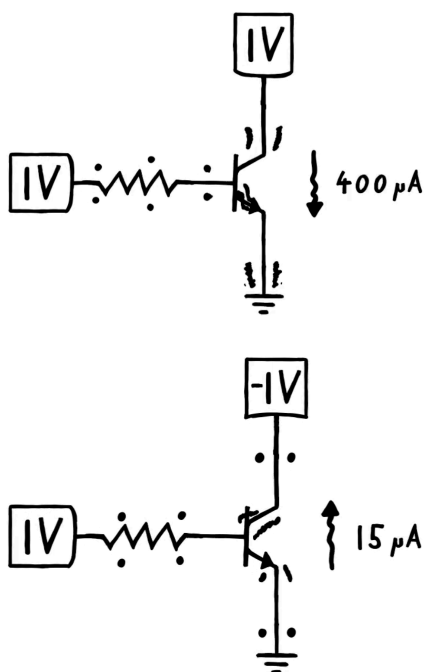

Let's imagine we isolate our transistor and apply 1 V to the base via a 100k resistor, 1 V to the collector and 0 V to the emitter. **This will cause around 400 μ A to flow between collector and emitter in what we call the transistor's forward active mode.**

Now, if we drop the collector voltage to -1 V, you'd expect to see the same amount of current flow in the opposite direction, right? **But in reality, that current will be much, much smaller – just around 15 μ A in what we call the transistor's reverse active mode.**

This explains why our sine wave gets morphed into a rounded sawtooth: because the transistor speeds up one oscillation phase considerably more than the other by sinking more current than it sources. But since the distortion is not too intense (at least for my taste), I think we can write this off as an okay compromise.

PITCH ENVELOPE

Great, so now that we're able to control the kick's pitch with a voltage, we can give it a quick, punchy envelope. For that, we'll set up a really basic envelope generator.

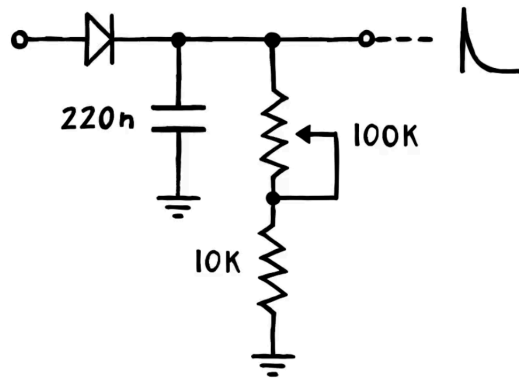

It works like this. If we apply our trigger to the input diode, current will flow into the 220 nF capacitor, instantly filling it up. Then, when the voltage pulse disappears, the charge inside the cap will drain out via the resistance to ground. **At the output node, this will result in a gradually falling voltage curve – with its steepness depending on the resistance we dial in using the potentiometer.** Great! But before we can send this into our transistor, we need to isolate the output node.

That's because if we don't, current will drain out of the cap through that output node, interfering with the controlled discharging process. Normally, I'd use an op amp buffer here – but in this case, we can actually be a bit more efficient and use an NPN transistor instead. Here's how that would work when we integrate the envelope into our setup.⁹

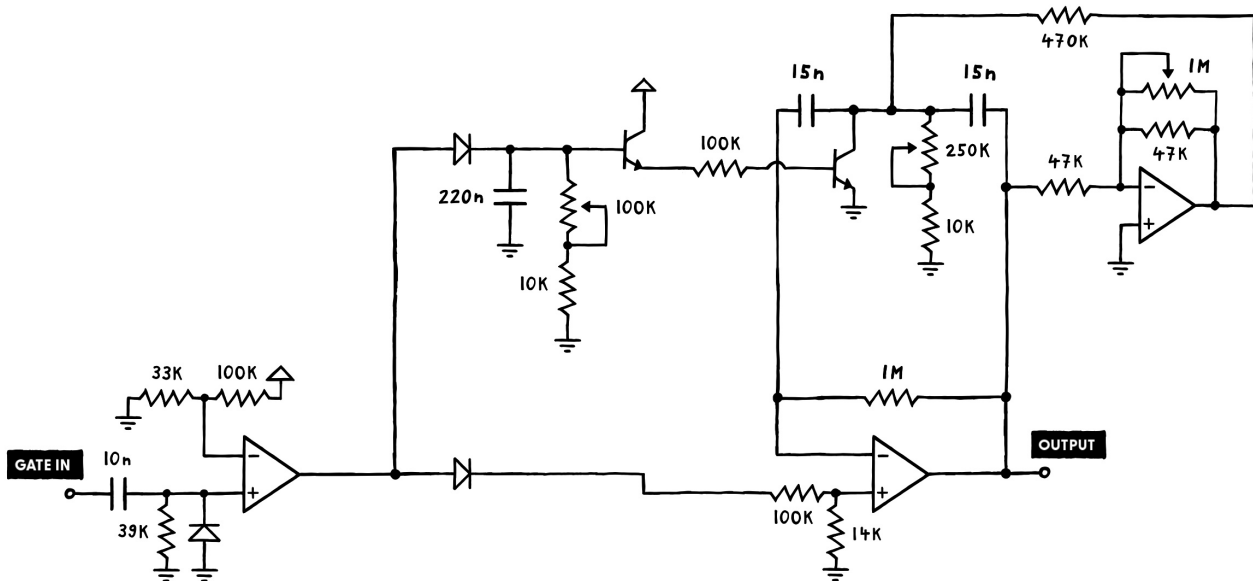

⁹ You can try this chapter's circuit in a simulator. I've already set it up for you [right here](#). You can change all values by double clicking on components.

First, we connect the input node to the gate-to-trigger converter. Then, we hook the output node up to an NPN transistor, which we'll set up as an emitter follower. (Meaning that we tie its collector to the positive rail and its emitter to the node where we need the envelope's buffered output.) **This way, the envelope can do its thing without interference, because the transistor copies the envelope's output voltage and pushes it into the 100k resistor.** Note that this only works for positive voltages here – so no worries, op amp buffers aren't obsolete.

Now, if you'd set this up on your breadboard and tested it, it would work, but also sound pretty horrible. **That's because for most of the envelope's curve, our transistor opens up so wide that the oscillation frequency goes through the roof.** To fix this, we'll simply add a 2k baseline resistance between the transistor and ground. This way, we give the pitch a hard ceiling at around 250 Hz. (This is also referred to as reducing the pitch envelope depth.) And because we might want to dial this down even further, we'll also add a 10k series potentiometer.

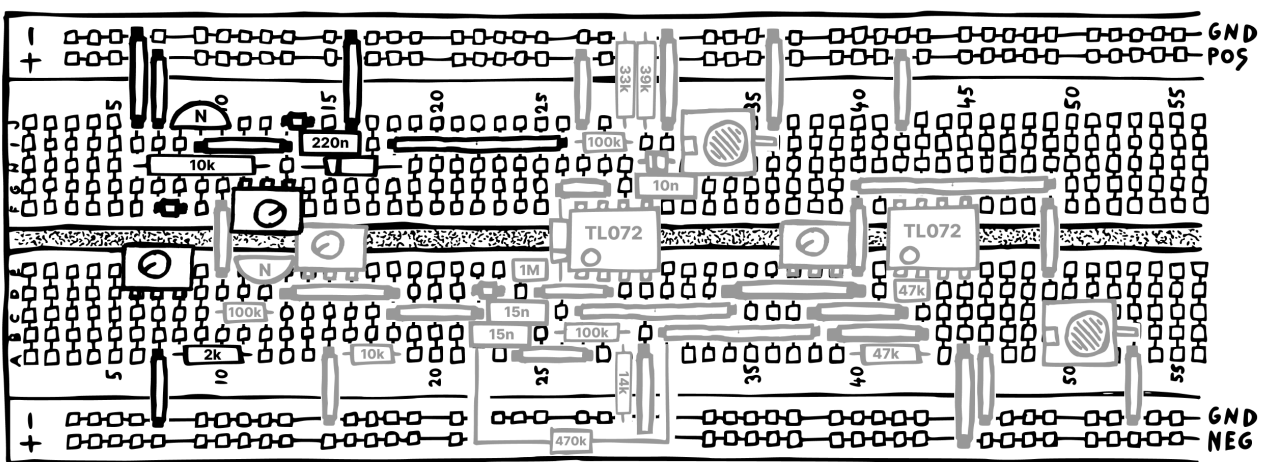
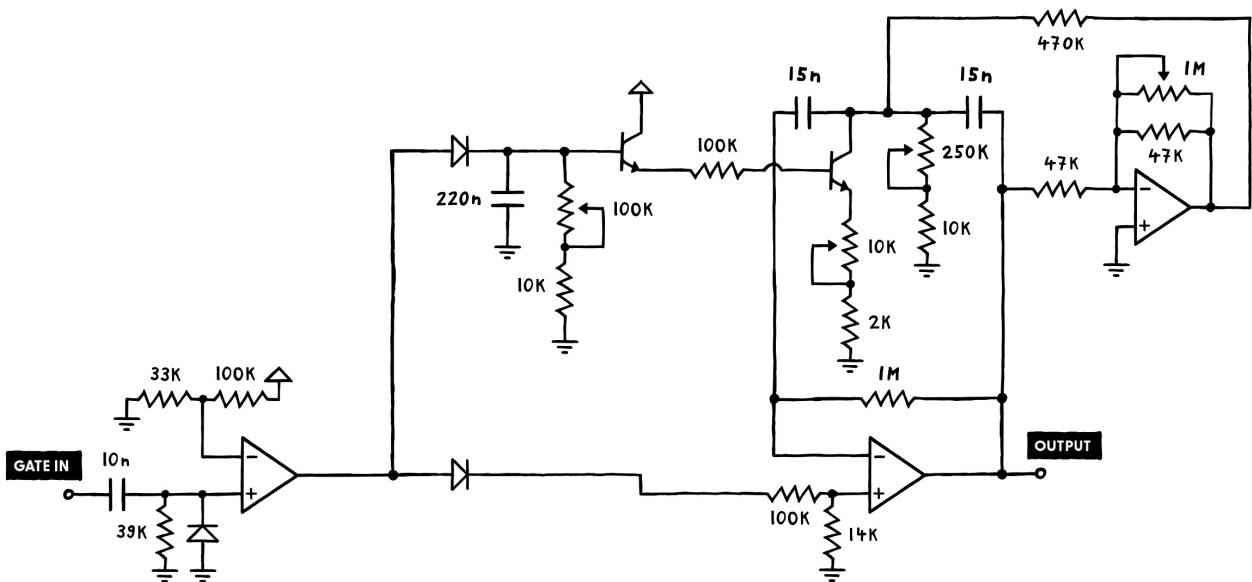

Once you've set this up, you should be able to adjust the pitch envelope's decay & depth over a pretty wide range.¹⁰ Though you might notice that at any setting, the transition between pitch envelope and base pitch is pretty abrupt.

¹⁰ Note that you can extend the decay by using a bigger capacitor.

somewhere slightly above 0 V. **So to get current flowing through it at all, the base voltage needs to be significantly higher than that.** When it's reverse active, though, the collector will go a good deal below 0 V, so the base voltage can basically idle slightly above the 0 V line and current will flow regardless.

By connecting the 1M resistor to the transistor's collector, we compensate for this. Because while the collector voltage is high, we give the 5.6 nF capacitor a little push, so that the base voltage rises high enough for current to flow. And when the collector voltage goes low, we restrain the cap a little to not waste precious current.

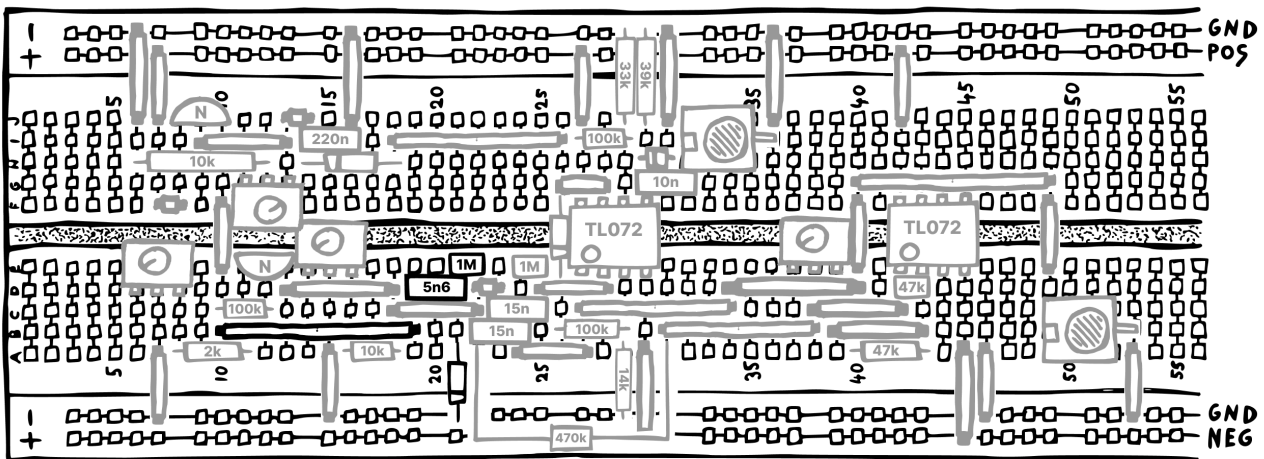

For comparison, check again what our kick sounds like without the added capacitor – and then add the cap. Once you do that, the drop down to the base pitch should become a little smoother. Great! (Of course you could intensify this effect by increasing the size of the capacitor.)

PITCH CV

Either way: with the previous adjustment, we've now got a perfectly usable kick drum. And while we could leave it here, I'd really like to add a couple bonus features. The first one of which being a dedicated CV input for the base pitch. At first glance, this might seem like a total piece of cake: simply add another 100k resistor to the pitch control transistor and we're done – right?

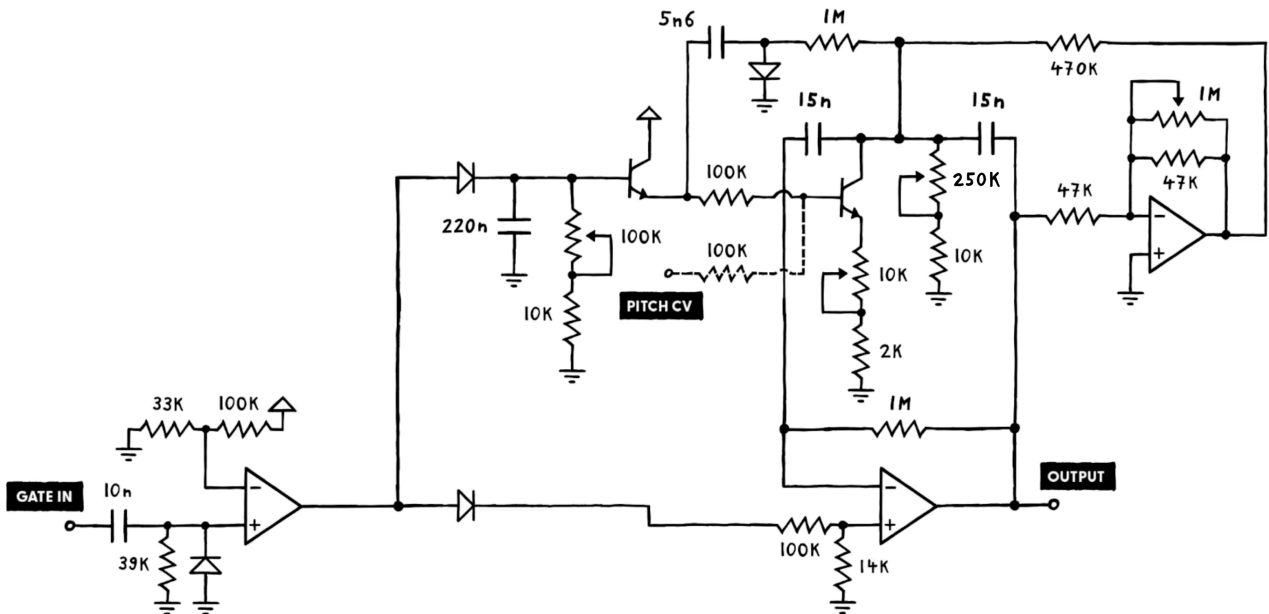

Well, if you'd try this, you'd quickly notice that it doesn't sound too great: the pitch envelope loses some of its punch, and it slides upwards weirdly. What's up with that? **Well, the problem is that our CV input is competing with the envelope generator, as both are trying to set the oscillator's pitch directly.** This means that neither can do their job properly. To fix it, we need to make them work together. Here's how.

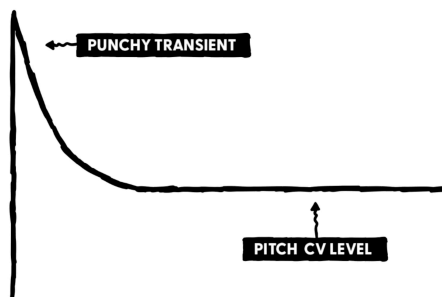

Instead of applying the incoming CV to the oscillator directly, we'll use it as the baseline to which our envelope drops down to. This way, the envelope's behavior is unaltered right after the trigger hits, ensuring that we get our nice, punchy transient – but allowing the pitch CV to take control right after. Sounds great in theory – but how do we pull this off? It's actually fairly simple: with a PNP transistor set up as an emitter follower.

If we add it to our envelope like shown below, then the capacitor is only allowed to discharge to the voltage we apply to the PNP's base.¹²

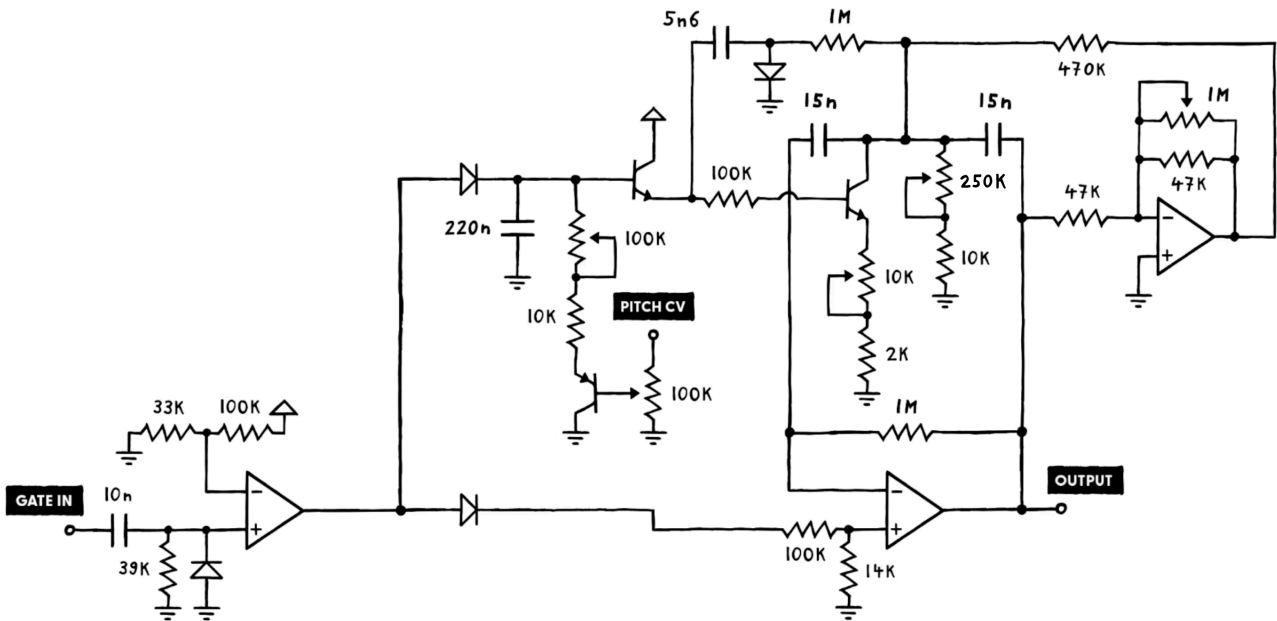

That's because that PNP only passes current between emitter and collector if the emitter voltage is higher than the base voltage. Once they're (almost) the same, the current flow will stop. Now, to give ourselves some control over how strongly the pitch CV affects the kick, we'll route that CV through a variable voltage divider. That way, we can dial in any ratio between 0 and 1.

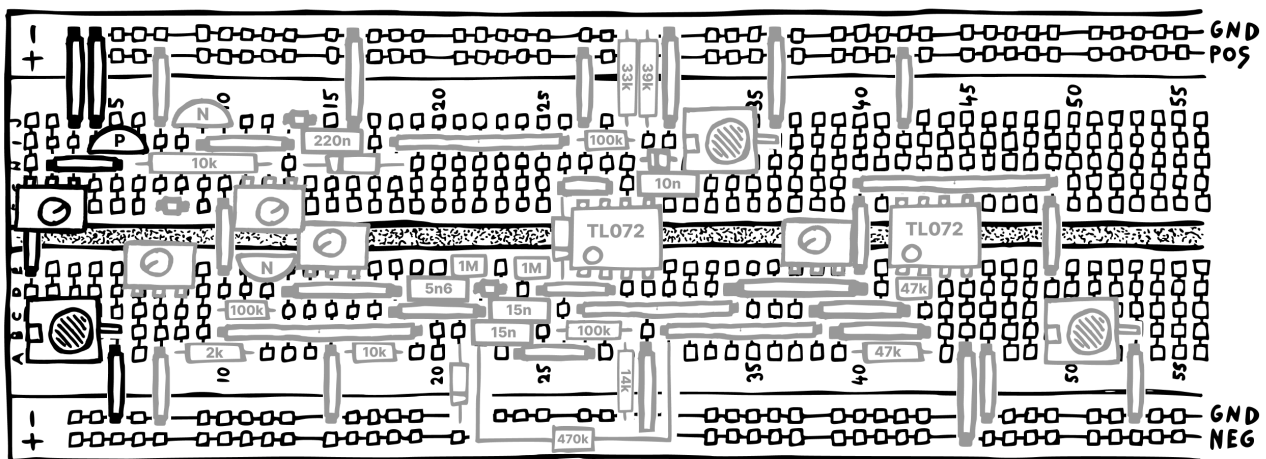

You can test this by sending a CV signal from your sequencer into the new pitch CV input. Of course this simplistic implementation does not adhere to the volt per octave standard – but I think it's pretty useful regardless.

¹² You can try this chapter's circuit in a simulator. I've already set it up for you [right here](#). You can change all values by double clicking on components.

ACCENT CV

Next, I'd like to add a CV input for the kick's accent level. Because right now, every hit has the same intensity, which does sound a little mechanical. **To change that, we'll simply have to manipulate the size of the voltage spike coming from our gate-to-trigger converter.** Because as we saw earlier, the size of that spike determines the initial volume of the kick hit. Great, but how do we do that using a control voltage?

Simple: we lean on our new friend, the PNP transistor. If we set it up as an emitter follower again, apply the accent CV to its base and the trigger to the resistor, we're already in business.¹³

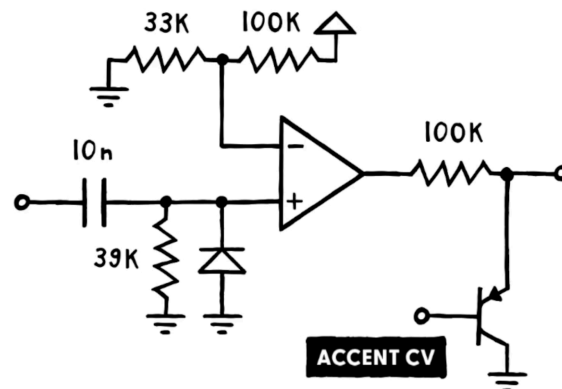

That's because if the voltage at the resistor is significantly higher than the base voltage, the transistor will sink so much current that the emitter voltage drops to a value slightly above the base voltage.

Great! There's just one small issue: because of the resistor, our implementation has a significant output impedance. It can't supply a lot of current. This is not ideal, since it has a big impact on how the rest of our circuit behaves. **There's an easy fix, though: we'll simply buffer the output with an NPN transistor – just like we did for our envelope.** This way, we lower the output impedance drastically, allowing the envelope and trigger input to work as expected.

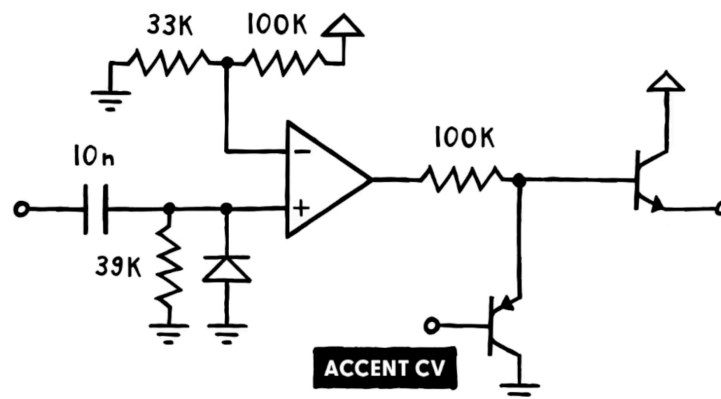

¹³ You can try this chapter's circuit in a simulator. I've already set it up for you [right here](#). You can change all values by double clicking on components.

If you'd try this, you'd notice that while it does work in principle, the kick is almost inaudible for lower CV levels. So we'll want to improve the CV range. Thankfully, doing that is very easy. We just have to add another resistor between the 100k and the PNP's emitter. This way, the voltage after the 100k will always be higher than the one at the emitter.

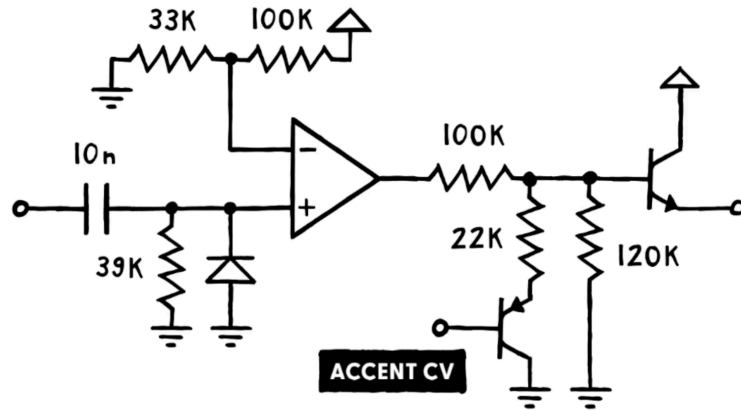

That's because the added resistance creates a secondary voltage drop before the PNP's emitter. So the bigger that resistor, the more we raise the minimum voltage level above it. When testing this, I found that a 22k resistor works best here – resulting in a 2 V spike at the output when the accent CV is 0.

In addition to this, I also decided to set up a 120k resistor to ground in parallel. Why? Because traditionally, the accent CV for a kick maxes out at 5 V – so even if we apply a higher voltage, the intensity should stay the same. **By bridging the 22k and PNP transistor with the 120k resistor, we ensure that the trigger can never go significantly beyond 5 V, even if the accent CV is higher than 5 V (or there is no accent CV applied at all).** That's because the 120k acts as a maximum resistance for the voltage divider.

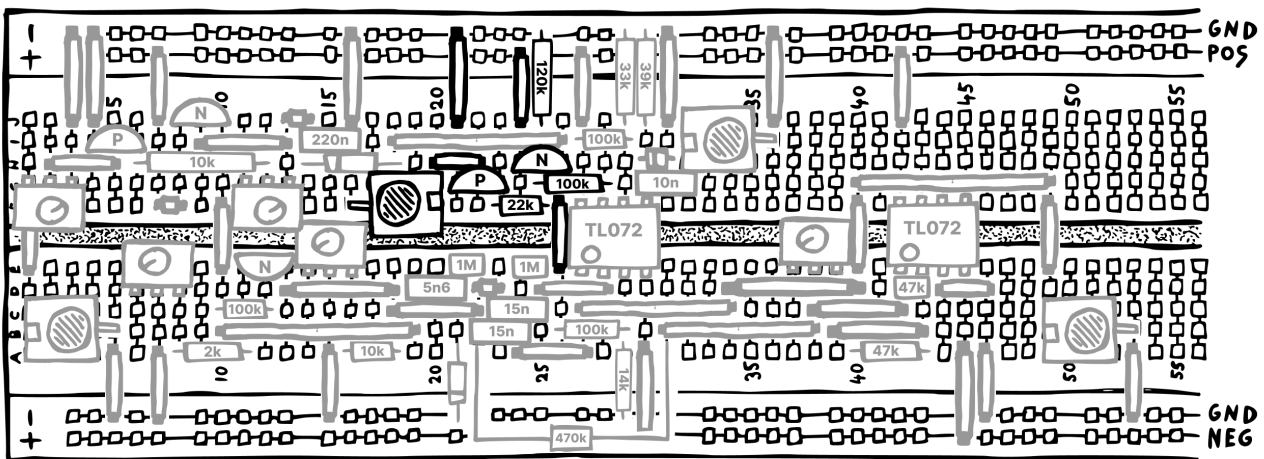

When you test this with CV coming from your sequencer, you should get an audible kick even at the minimum CV level. Plus, if you disconnect the accent CV, the kick should not get louder than at the maximum CV level.

DISTORTION STAGE

We'll set up an op amp-based, variable distortion stage that doubles as a buffer. All we need for that, in addition to the op amp, are a resistor, a potentiometer, and two diodes.

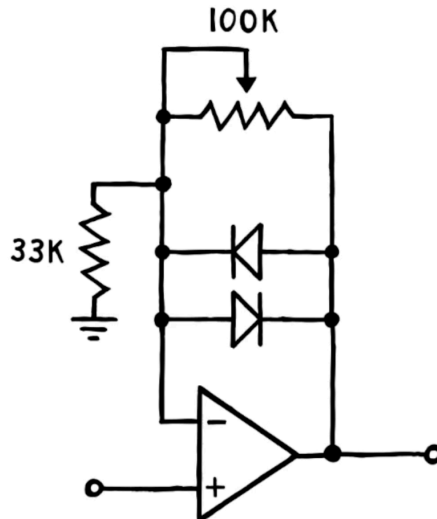

Here's how it works. If the potentiometer is dialed all the way down, there is a direct, unimpeded connection between the op amp's output and inverting input, which turns it into a straight buffer. So it simply replicates the signal applied to the non-inverting input. But as we dial that pot up, things get interesting. Because now, the two resistances form a voltage divider. Which, by itself, would simply increase the op amp's gain and therefore the output volume.

But since we also have these two diodes in the feedback path, something strange happens. **The output gain is only increased for those parts of the signal that are too low to open the diodes.** Because as soon as the op amp's output goes above 600 mV or below -600 mV, the diodes open up and the setup works as a straight buffer again. This way, we create a dent in the output wave whenever it crosses the 0 V-line.

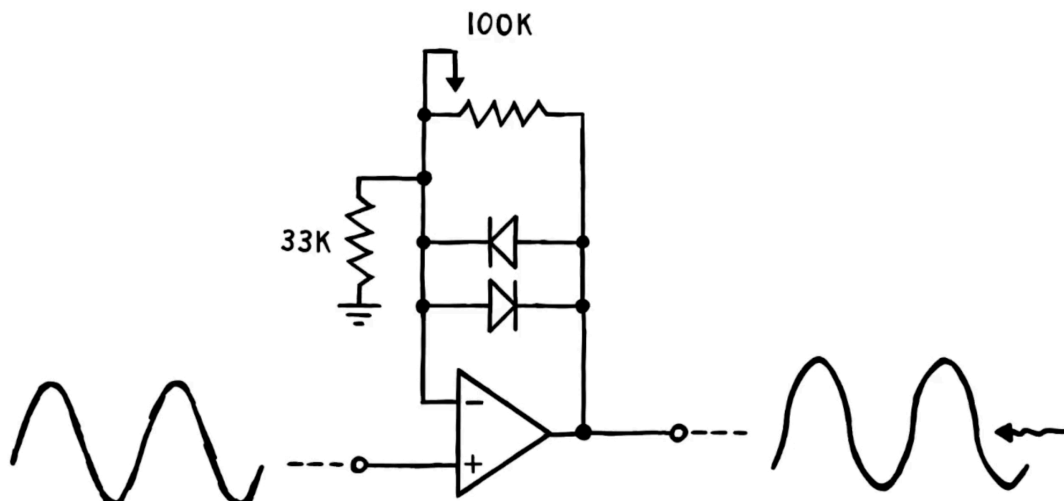

COMPONENTS & CONCEPTS

APPENDIX

In this section, we'll take a closer look at the components and elemental circuit design concepts we're using to build our module. Check these whenever the main manual moves a bit too fast for you!

THE BASICS: RESISTANCE, VOLTAGE, CURRENT

There are three main properties we're interested in when talking about electronic circuits: **resistance, voltage and current**. To make these less abstract, we can use a common beginner's metaphor and compare the flow of electrons to the flow of water through a pipe.

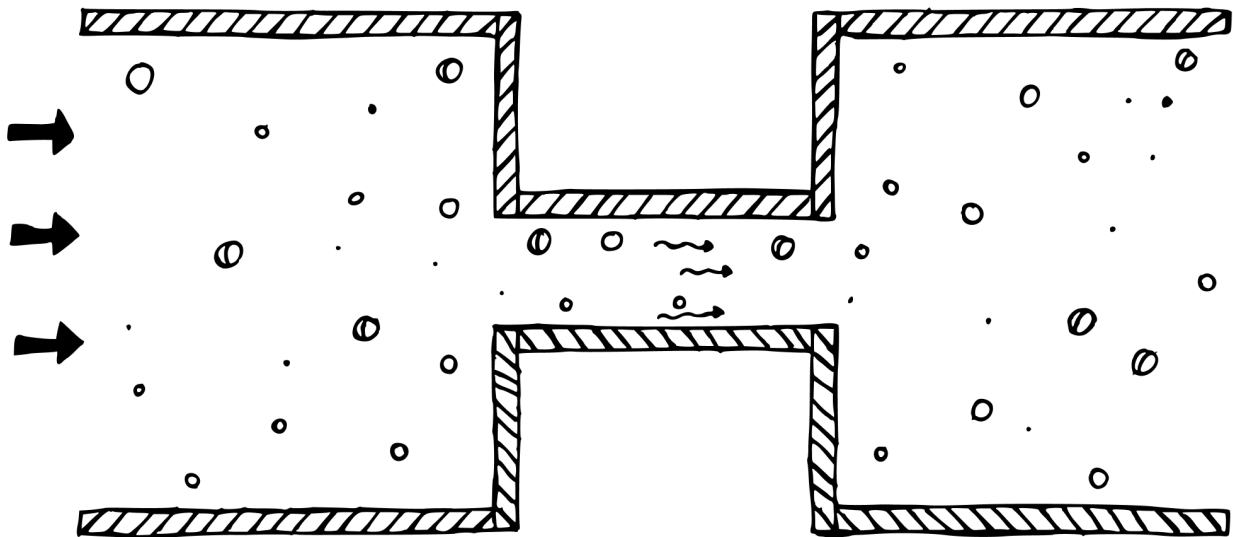

In that metaphor, resistance would be the width of a pipe. The wider it is, the more water can travel through it at once, and the easier it is to push a set amount from one end to the other. Current would then describe the flow, while voltage would describe the pressure pushing the water through the pipe. You can probably see how all three properties are interlinked: **more voltage increases the current, while more resistance to that voltage in turn decreases the current.**

RESISTORS

While a conductive wire is like a very big pipe where lots of water can pass through, a resistor is like a narrow pipe that restricts the amount of water that can flow. The narrowness of that pipe is equivalent to the resistance value, measured in ohms (Ω). The higher that value, the tighter the pipe.

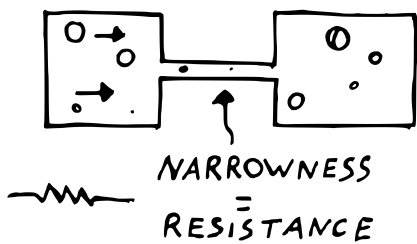

Resistors have two distinctive properties: linearity and symmetry. Linearity, in this context, means that for a doubling in voltage, the current flowing will double as well. Symmetry means that the direction of flow doesn't matter – resistors work the same either way.

On a real-life resistor, you'll notice that its value is not printed on the outside – like it is with other components. Instead, it is indicated by colored stripes¹⁵ – along with the resistor's tolerance rating. In addition to that, the resistor itself is also colored. Sometimes, depending on who made the resistor, this will be an additional tolerance indicator.

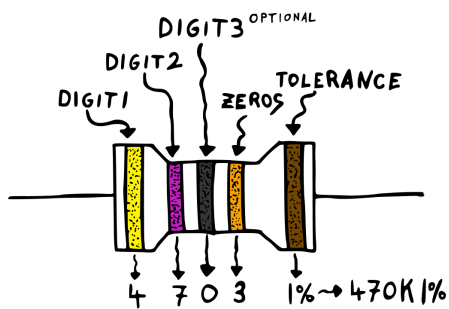

For the resistors in this kit, a yellow body tells you that the actual resistance value might be $\pm 5\%$ off. A dark blue body indicates $\pm 1\%$ tolerance. Some kits will also contain light blue $\pm 0.1\%$ resistors to avoid the need for manual resistor matching.

While in the long run, learning all these color codes will be quite helpful, you can also simply use a multimeter to determine a resistor's value.

¹⁵ For a detailed breakdown, look up [resistor color coding](#). There are also calculation tools available.

CAPACITORS

A capacitor is a bit like a balloon that you can attach to the open end of a pipe. If there's some pressure in the pipe, the balloon will fill up with water until the pressure equalizes. (Since the balloon needs some space to expand into, both of the capacitor's legs need to be connected to points in your circuit.)

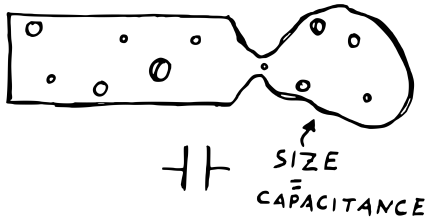

Then, should the pressure in the pipe drop, the balloon releases the water it stored into the pipe. The maximum size of the balloon is determined by the capacitor's capacitance, which we measure in farad (F). There are quite a few different types of capacitors: electrolytic, foil, ceramic, tantalum etc. They all have their unique properties and ideal usage scenarios – but the most important distinction is if they are polarized or not.

You shouldn't use polarized capacitors against their polarization (applying a negative voltage to their positive terminal and vice versa) – so they're out for most audio-related uses like AC coupling, high- & low-pass filters etc.

Unlike resistors, capacitors have their capacitance value printed onto their casing, sometimes together with a maximum operating voltage. **Be extra careful here!** That voltage rating is important. Your capacitors can actually explode if you exceed it! So they should be able to withstand the maximum voltage used in your circuit. If they're rated higher – even better, since it will increase their lifespan. No worries though: the capacitors in this kit are carefully chosen to work properly in this circuit.

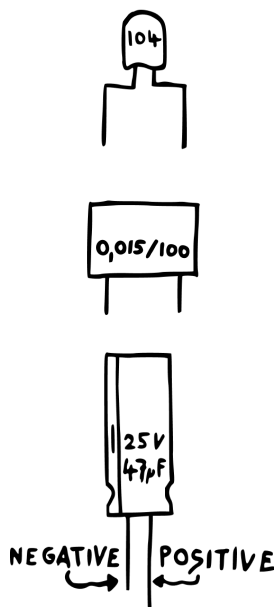

Ceramic capacitors usually come in disk- or pillow-like cases, are non-polarized and typically encode their capacitance value.¹⁶ Annoyingly, they rarely indicate their voltage rating – so you'll have to note it down when buying them.

Film capacitors come in rectangular, boxy cases, are non-polarized and sometimes, but not always, directly indicate their capacitance value and their voltage rating without any form of encoding.¹⁷

Electrolytic capacitors can be identified by their cylinder shape and silver top, and they usually directly indicate their capacitance value and their voltage rating. They are polarized – so make sure you put them into your circuit in the correct orientation.

¹⁶ For a detailed breakdown, look up [ceramic capacitor value code](#). There are also calculation tools available.

¹⁷ If yours do encode their values, same idea applies here – look up [film capacitor value code](#).

DIODES

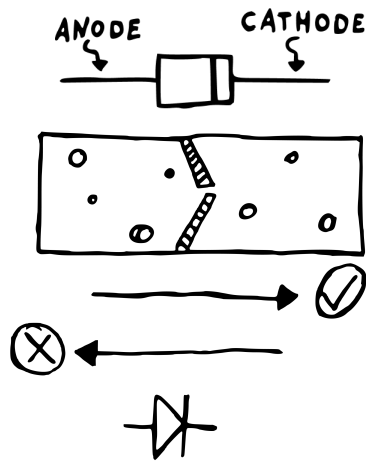

Diodes are basically like one-way valves. Current can only pass through in one direction – from anode to cathode. That direction is indicated by the arrow in the diode symbol and by a black stripe on the diode’s casing. So any current trying to move in the opposite direction is blocked from flowing.

There are a few quirks here, though. For one, the diode will only open up if the pushing force is strong enough. Generally, people say that’s 0.7 V, but in reality, it’s usually a bit lower. Also, diodes don’t open up abruptly – they start conducting even at much lower voltages, although just slightly.

There are a lot of different diode types: Zener, Schottky, rectifier, small signal etc. They all have their unique properties and ideal usage scenarios – but usually, a generic 1N4148 small signal diode will get the job done.

SCHMITT TRIGGER INVERTERS

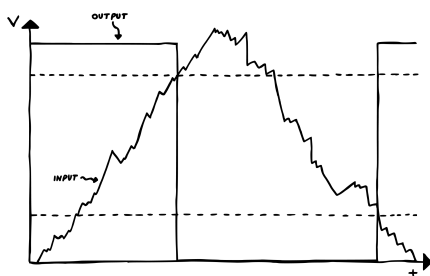
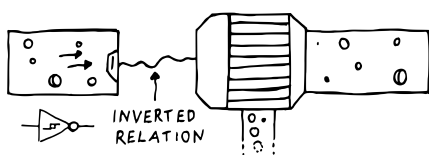

You can think of a Schmitt trigger inverter as two separate things. On the left, there’s a sensor that measures the pressure inside an attached pipe. On the right, there is a water pump. This pump’s operation is controlled by the sensor. Whenever the pressure probed by this sensor is below a certain threshold, the pump will be working. If the pressure is above a second threshold, the pump won’t be working. Here’s a quick graph to visualize that. The squiggly line represents the voltage at the input, while the dotted line shows the voltage at the output. So every time we cross the upper threshold on our way up, and the lower one on our way down, the output changes its state. One thing that’s very important to keep in mind: no current flows into the sensor! It’s really just sensing the voltage without affecting it.

VOLTAGE DIVIDERS

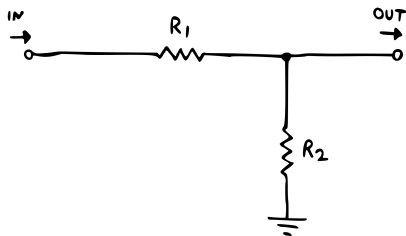

A voltage divider is really just two resistors set up like this: input on the left, output on the right. If R_1 and R_2 are of the same value, the output voltage will be half of what the input voltage is. How does it work?

Let's use our analogy again: so we have a pipe on the left, where water is being pushed to the right with a specific amount of force. Attached to it is a narrow pipe, representing R_1 , followed by another wide pipe. Then at the bottom, there's another narrow pipe, representing R_2 , where water can exit the pipe system. Finally, imagine we've set up a sensor measuring the voltage in the right hand pipe.

First, think about what would happen if R_2 was completely sealed off. Our sensor would tell us that **the pressure on the right side is exactly the same as the pressure on the left**. Because the pushing force has nowhere else to go.

On the other hand, imagine R_2 would just be a wide opening. Then **the pressure on the right would be 0**, because it'd all escape through that opening. But what happens if R_2 is neither completely closed off nor wide open? Then the pressure would be retained to varying degrees, depending on the narrowness of the two resistor paths.

If pipe R_1 is wide and pipe R_2 is narrow, most of the pressure will be retained. But if it's the reverse, the pressure level will be only a tiny fraction. And if R_1 and R_2 are identical, **the pressure will be exactly half of what we send in**.

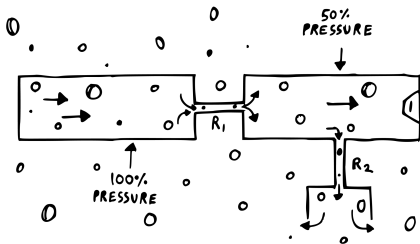
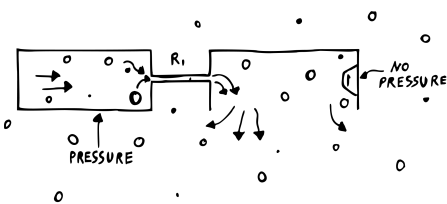
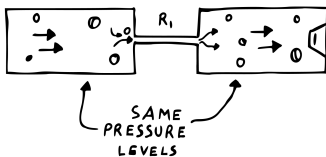

POTENTIOMETERS

Potentiometers can be used as variable resistors that you control by turning a knob. But, and that's the handy part, they can also be set up as variable voltage dividers. To see how that works, let's imagine we open one up.

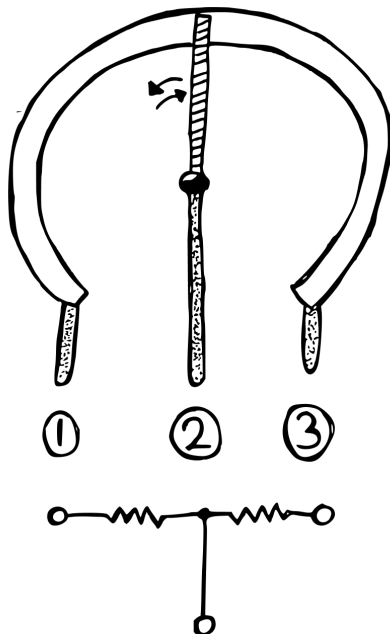

Inside, we would find two things: a round track of resistive material with connectors on both ends plus what's called a wiper. This wiper makes contact with the track and also has a connector. It can be moved to any position on the track. Now, the resistance value between the two track connectors is always going to stay exactly the same. That's why it's used to identify a potentiometer: as a 10k, 20k, 100k etc. But if you look at the resistance between either of those connectors and the wiper connector, you'll find that this is completely dependent on the wiper's position.

The logic here is really simple: **the closer the wiper is to a track connector, the lower the resistance is going to be between the two.** So if the wiper is dead in the middle, you'll have 50 % of the total resistance between each track connector and the wiper.

From here, you can move it in either direction and thereby shift the ratio between the two resistances to be whatever you want it to be. By now, you might be able to see how that relates to our voltage divider. If we send our input signal to connector 1 while grounding connector 3, we can pick up our output signal from the wiper. Then by turning the potentiometer's knob, we can adjust the voltage level from 0 to the input voltage – and anything in between.

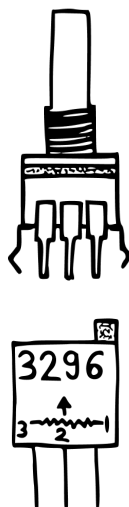

In these kits, you will encounter different types of potentiometers. First, there's the regular, full-size variant with a long shaft on top. These are used to implement user-facing controls on the module's panel and they usually – but not always – indicate their value directly on their casing. Sometimes, they'll use a similar encoding strategy as capacitors, though.¹⁸

Second, we've got the trimmer potentiometer, which is usually much smaller and doesn't sport a shaft on top. Instead, these have a small screw head which is supposed to be used for one-time set-and-forget calibrations. Trimmers usually encode their value.

¹⁸ Look up [potentiometer value code](#) for a detailed breakdown.

AC COUPLING

What is AC coupling – and how does it work? Imagine two adjacent pipes with a balloon between them. Now, no water can get from one pipe into the other, since it's blocked by the balloon. But, and that's the kicker, **water from one side can still push into the other by bending and stretching the balloon, causing a flow by displacement.**

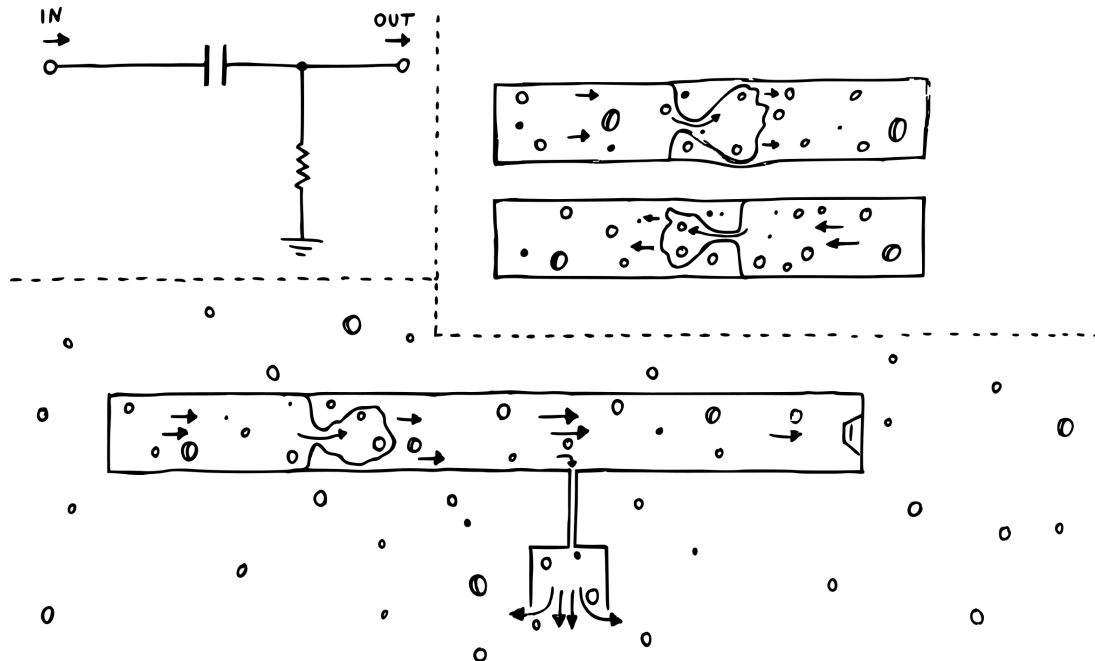

Next, we'll bring in a resistor after the coupling point, going straight to ground. **This acts like a kind of equalizing valve.** Now imagine we apply a steady 5 V from one side. Then on the other side, we'll read 0 V after a short amount of time. Why? Because we're pushing water into the balloon with a constant force, causing it to stretch into the other side, displacing some water. If we didn't have the equalizing valve there, we'd simply raise the pressure. But since we do have it, the excess water can drain out of the system. Until the pressure is neutralized, and no water is actively flowing anymore.

Okay, so now imagine that the voltage on the left hand side starts oscillating, let's say between 4 V and 6 V. When we start to go below 5 V, the balloon will begin contracting, basically pulling the water to the left. This will create a negative voltage level in the right hand pipe – like as if you're sucking on a straw, making the voltage there drop below 0 V. Then, once the pressure on the other side rises above 5 V, the balloon will inflate and stretch out again, pushing water to the right. And the pressure in the right hand pipe will go positive, making the voltage rise above 0 V. **We've re-centered our oscillation around the 0 V line.** Okay, but what about the resistor? If current can escape through it, doesn't that mess with our oscillation? Well, technically yes, but practically, we're choosing a narrow enough pipe to make the effect on quick pressure changes negligible!

OP AMPS

Op amps might seem intimidating at first, but they're actually quite easy to understand and use. The basic concept is this: every op amp has two inputs and one output. Think of those inputs like voltage sensors. You can attach them to any point in your circuit and they will detect the voltage there without interfering. **No current flows into the op amps inputs – that's why we say their input impedance is very high.** Near infinite, actually. Okay, but why are there two of them?

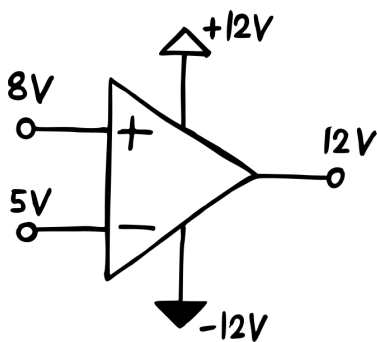

The key here is that op amps are essentially differential amplifiers. This means that they only amplify the difference between their two inputs – not each of them individually. If that sounds confusing, let's check out a quick example. So we'll imagine that one sensor – called the non-inverting input – is reading 8 V from somewhere. The other sensor – called the inverting input – reads 5 V. Then, as a first step, the op amp will subtract the inverting input's value from the non-inverting input's value. Leaving us with a result of 3. (Because 8 minus 5 is 3.) **This result then gets multiplied by a very large number – called the op amp's gain.** Finally, the op amp will try to push out a voltage that corresponds to that multiplication's result.

But of course, the op amp is limited here by the voltages that we supply it with. If we give it -12 V as a minimum and +12 V as a maximum, the highest it can go will be +12 V. So in our example, even though the result of that multiplication would be huge, the op amp will simply push out 12 V here and call it a day.

The handy thing though about op amp outputs is that they draw their power directly from the power source. This means that they can supply lots of current while keeping the voltage stable. **That's why we say an op amp has a very low output impedance.**

OP AMP BUFFERS/AMPLIFIERS

Buffering, in the world of electronics, means that we provide a perfect copy of a voltage without interfering with that voltage in the process. With an op amp-based buffer, the buffering process itself works like this. We use the non-inverting input to probe a voltage, while the inverting input connects straight to the op amp's output. **This creates what we call a negative feedback loop.** Think of it this way. We apply a specific voltage level to the non-inverting input – let's say 5 V.

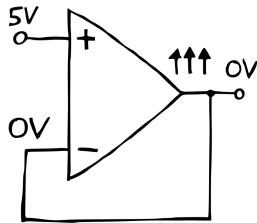

Before the op amp starts processing the voltages at its inputs, the output will be switched off. This means that **output and inverting input sit at 0 V at first.** So then, the op amp will subtract 0 from 5 and multiply the result by its gain. Finally, it will try and increase its output voltage to match the calculation's outcome.

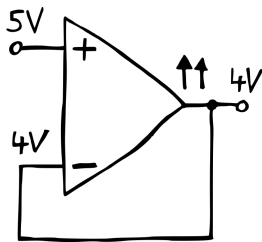

But as it's pushing up that output voltage, the **voltage at the inverting input will be raised simultaneously.** So the difference between the two inputs is shrinking down. Initially, this doesn't matter much because the gain is so large. As the voltage at the inverting input gets closer to 5 V though, the difference will shrink so much that in relation, the gain suddenly isn't so large anymore.

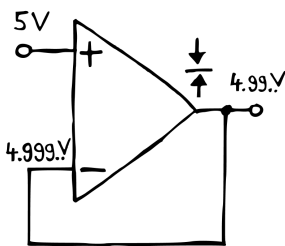

Then, the output will **stabilize at a voltage level that is a tiny bit below 5 V**, so that the difference between the two inputs multiplied by the huge gain gives us exactly that voltage slightly below 5 V. And this process simply loops forever, keeping everything stable through negative feedback. Now if the voltage at the non-inverting input changes, that feedback loop would ensure that the output voltage is always following. So that's why this configuration works as a buffer: the **output is simply following the input.**

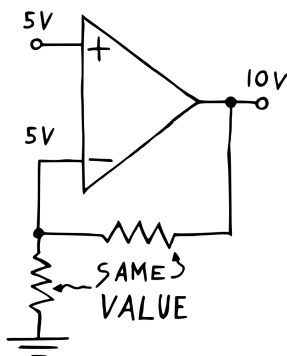

How about amplifying a signal though? To do that, we'll have to turn our buffer into a proper non-inverting amplifier. We can do that by replacing the straight connection between inverting input and output with a voltage divider, forcing the op amp to work harder. Here's how that works. Say we feed our non-inverting input a voltage of 5 V. Now, **the output needs to push out 10 V in order to get the voltage at the inverting input up to 5 V.** We call this setup a non-inverting

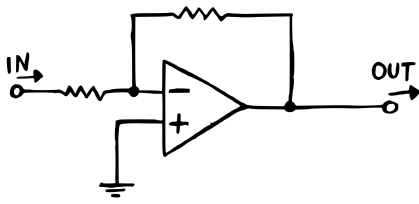

amplifier because the output signal is in phase with the input.

For an inverting buffer/amplifier, the input signal is no longer applied to the non-inverting input. Instead, that input is tied directly to ground. So it'll just sit at 0 V the entire time. The real action, then, is happening at the inverting input. Here, we first send in our waveform through a resistor. Then, the inverting input is connected to the op amp's output through another resistor of the same value.

How does this work? Well, let's assume that we're applying a steady voltage of 5 V on the left. Then, as we already know, the op amp will subtract the inverting input's voltage from the non-inverting input's voltage, leaving us with a result of -5 V. Multiply that by the huge internal gain, and the op amp will try to massively decrease the voltage at its output.

But as it's doing that, an increasingly larger current will flow through both resistors and into the output. Now, as long as the pushing voltage on the left is stronger than the pulling voltage on the right, some potential (e.g. a non-zero voltage) will remain at the inverting input. Once the output reaches about -5 V though, we'll enter a state of balance. Since both resistors are of the same value, the pushing force on the left is fighting the exact same resistance as the pulling force on the right. **So all of the current being pushed through one resistor is instantly being pulled through the other.**

And that means that the voltage at the inverting input will be lowered to about 0 V, allowing our op-amp to settle on the current output voltage level. So while we read 5 V on the left, we'll now read a stable -5 V at the op amp's output. Congrats – we've built an inverting buffer! **If we want to turn it into a proper amplifier, we'll simply have to change the relation between the two resistances.** By doing this, we can either increase (if you increase the right-hand resistor's value) or reduce (if you increase the left-hand resistor's value) the gain to our heart's content.

BIPOLAR JUNCTION TRANSISTORS

Bipolar junction transistors (or BJTs for short) come in two flavors: NPN and PNP. This refers to how the device is built internally and how it'll behave in a circuit. Apart from that, they look pretty much identical: a small black half-cylinder with three legs.

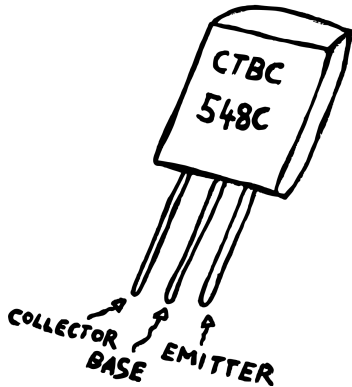

Let's take a look at the more commonly used NPN variant first. Here's how we distinguish between its three legs. **There's a collector, a base and an emitter.**¹⁹ All three serve a specific purpose, and the basic idea is that you control the current flow between collector and emitter by applying a small voltage²⁰ to the base. The relation is simple: **more base voltage equals more collector current.** Drop it down to 0 V and the transistor will be completely closed off. Sounds simple – but there are four important quirks to this.

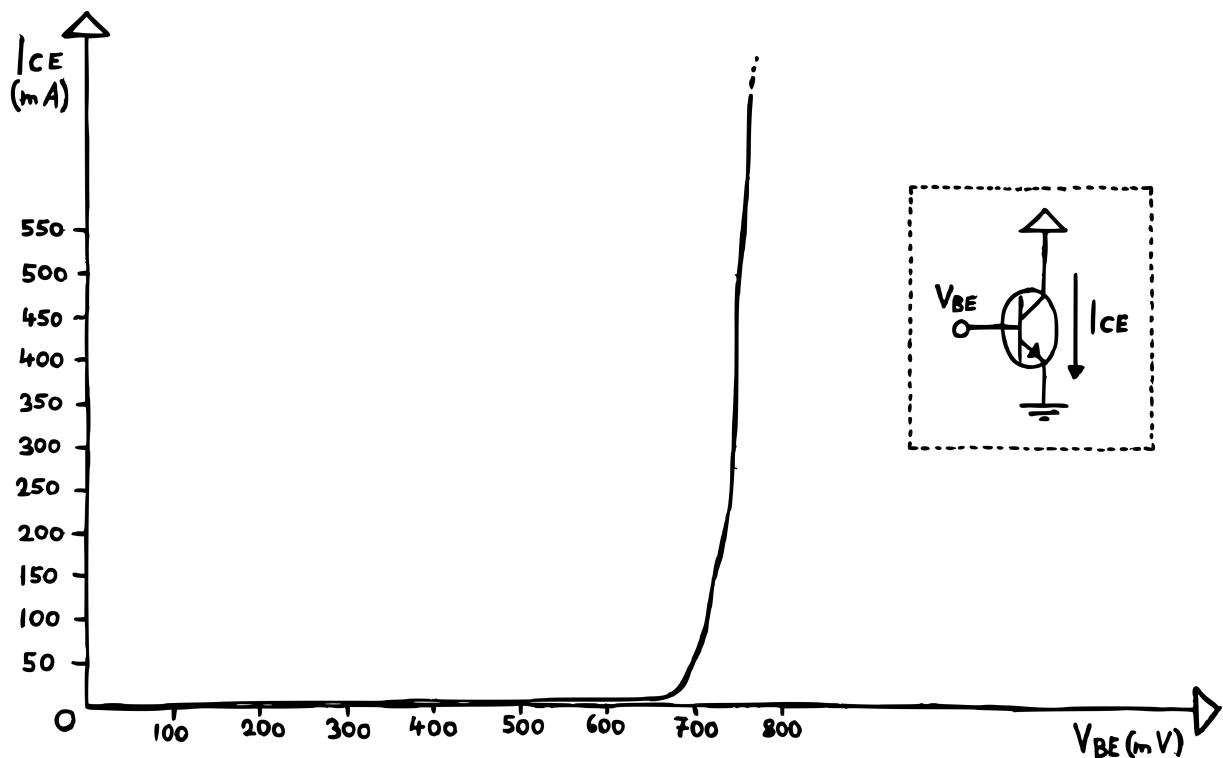

First, the relation between base voltage and collector current is exponential. Second, unlike a resistor, a BJT is not symmetrical – so we can't really reverse the direction of the

¹⁹ Please note that the pinout shown here only applies for the BC series of transistors. Others, like the 2N series, allocate their pins differently.

²⁰ The voltage is measured between base and emitter. So „a small voltage“ effectively means a small voltage **difference** between base and emitter!

collector current. (At least not without some unwanted side effects.) Third, also unlike a resistor, a BJT is not a linear device. Meaning that a change in collector voltage will not affect the collector current. And fourth, the collector current is affected by the transistor's temperature! The more it heats up, the more current will flow.

Now, for the PNP transistor, all of the above applies, too – except for two little details. Unlike with the NPN, **the PNP transistor decreases its collector current when the voltage at its base increases**²¹. So you have to bring the base voltage below the emitter to open the transistor up. Also, that collector current flows out of, not into the collector!

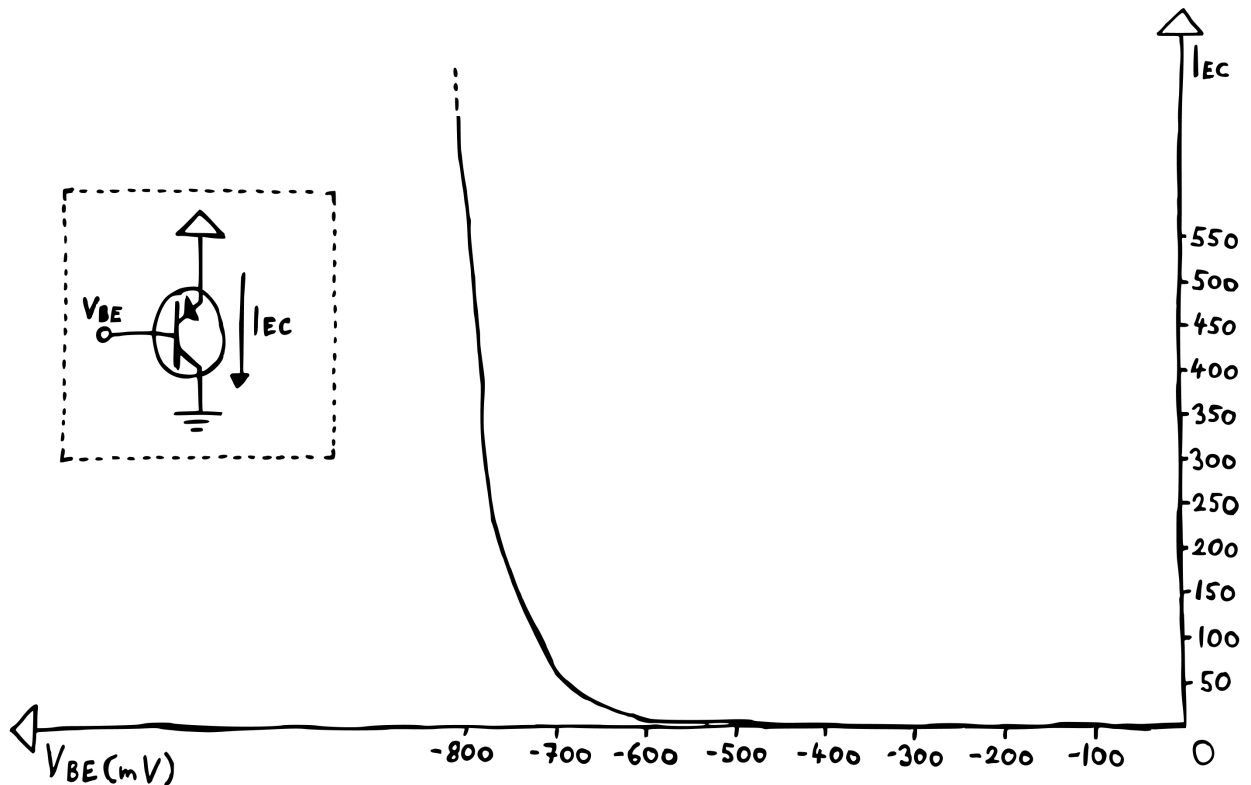

²¹ Again, the voltage is measured between base and emitter.

TOOLS APPENDIX

There are two types of tools that will help you tremendously while designing a circuit: multimeters and oscilloscopes. In this appendix, we'll take a quick look at each of these and explore how to use them.

MULTIMETERS

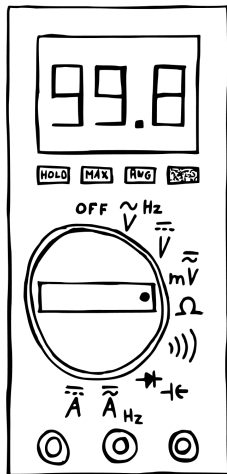

Multimeters come in different shapes and sizes, but the most common type is probably the hand-held, battery powered variant. It can measure a bunch of different things: voltage, current, resistance, continuity. Some have additional capabilities, allowing you to check capacitance, oscillation frequency or the forward voltage drop of a diode.

When shopping for one, you'll probably notice that there are really expensive models boasting about being TRUE RMS multimeters. For our purposes, this is really kind of irrelevant, so don't feel bad about going for a cheap model!

Using a multimeter is actually really straightforward. Simply attach two probes to your device – the one with a black cable traditionally plugs into the middle, while the red one goes into the right connector. Next, find whatever you want to measure and select the corresponding mode setting.

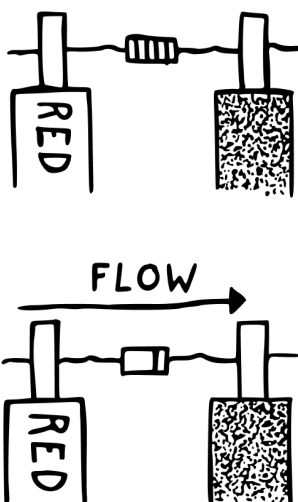

In some cases, it doesn't matter which probe you connect to which component leg or point in your circuit. This is true for testing resistors, non-polarized capacitors (foil/film, ceramic, teflon, glass etc.), continuity²² or AC voltage.

In others, you'll have to be careful about which probe you connect where. For testing the forward voltage drop of a diode, for example, **the multimeter tries to push a current from the red to the black probe**. Here, you'll have to make sure the diode is oriented correctly, so that it doesn't block that current from flowing. For testing a DC voltage, you want to make sure the black probe is connected to ground, while you use the red one to actually take your measurement.

²² Just a fancy word for saying that two points are electrically connected.

OSCILLOSCOPES

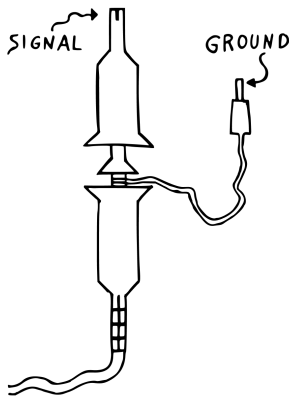
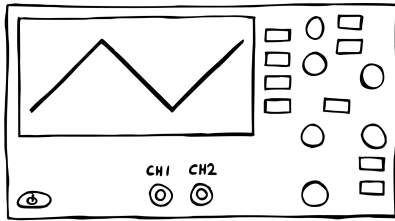

While multimeters are fairly cheap and compact, oscilloscopes are usually somewhat pricey and bulky. **If you're willing to make the investment, they are a huge help with the troubleshooting process, though.** Using one is, again, surprisingly straightforward – if you manage to work your way through the sometimes quite convoluted UI, especially on digital models.

To start using your scope, simply attach a probe to one of the channel inputs. These probes usually have two connectors on the other end: a big one that you operate by pulling the top part back – and a smaller one, which is usually a standard alligator clip. The latter needs to be connected to your circuit's ground rail, while you probe your oscillation with the former. Now what the oscilloscope will do is **monitor the voltage between the two connectors over time and draw it onto the screen as a graph.** Here, the x-axis is showing time, while the y-axis is showing voltage. You can use the device's scaling controls to zoom in on a specific part of your waveform.

Usually, digital oscilloscopes will also tell you a couple useful things about the signal you're currently viewing: minimum/maximum voltage level, oscillation frequency, signal offset. Some even offer a spectrum analyzer, which can be useful to check the frequencies contained in your signal.

ASSEMBLY APPENDIX

Before we get started, let's take a quick look at the complete **mki x es.edu Kick Drum** schematic (see next page). This is the version we used for the final module's design and PCB layout. Most components on the schematic have labels (like **R1**, **C1**, **VT1**, **VD1**, etc.) and values printed next to them. These labels help you identify each component on the actual PCB, which is especially useful for troubleshooting or modifications.

You'll also notice a few small additions that don't change the circuit's behavior, but protect it from improper use and other edge-case scenarios. Let's take a look at those.

PCB-only circuit additions

Reverse polarity protection

Connector **XP1** is the Eurorack power input. It's a 2x5 male header with a black shroud that prevents plugging the power cable in backwards. If the connector is somehow inserted incorrectly, the module could be damaged – so we added two Schottky diodes (**VD1** and **VD2**) for extra safety.

Diodes only conduct in one direction, so if the power rails are reversed, they simply block current from flowing. We specifically use Schottky diodes here because of their low forward voltage drop – a normal silicon diode would waste more voltage, which could affect the circuit's operation.

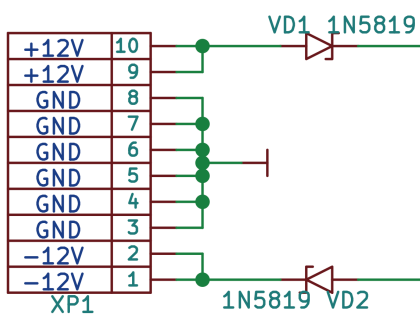

Power filtering

On the positive and negative supply rails, two 10 ohm resistors (**R14** and **R15**) work together with decoupling capacitors **C1** – **C4** to keep the module's internal voltages stable. These capacitors act as small charge reservoirs: they store energy and release it when the system's power supply dips or fluctuates.

In combination with **R14** and **R15**, the large 47 μF capacitors (**C1** and **C2**) smooth out slow, low-frequency variations, while the smaller **C3** and **C4** handle fast transients – things like switching noise or short voltage spikes created by other modules in the rack.

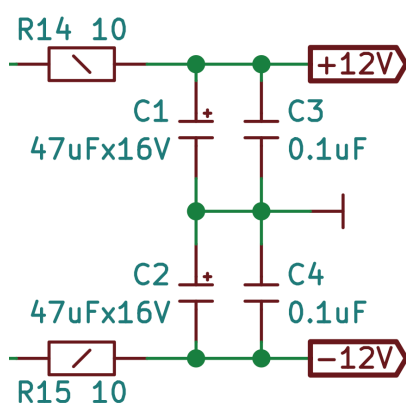

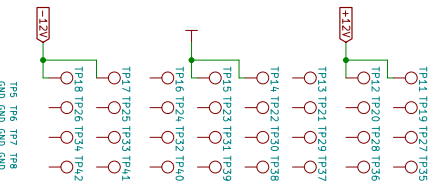
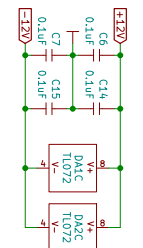
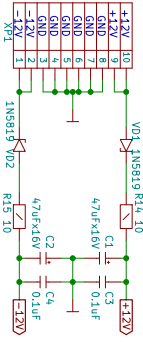
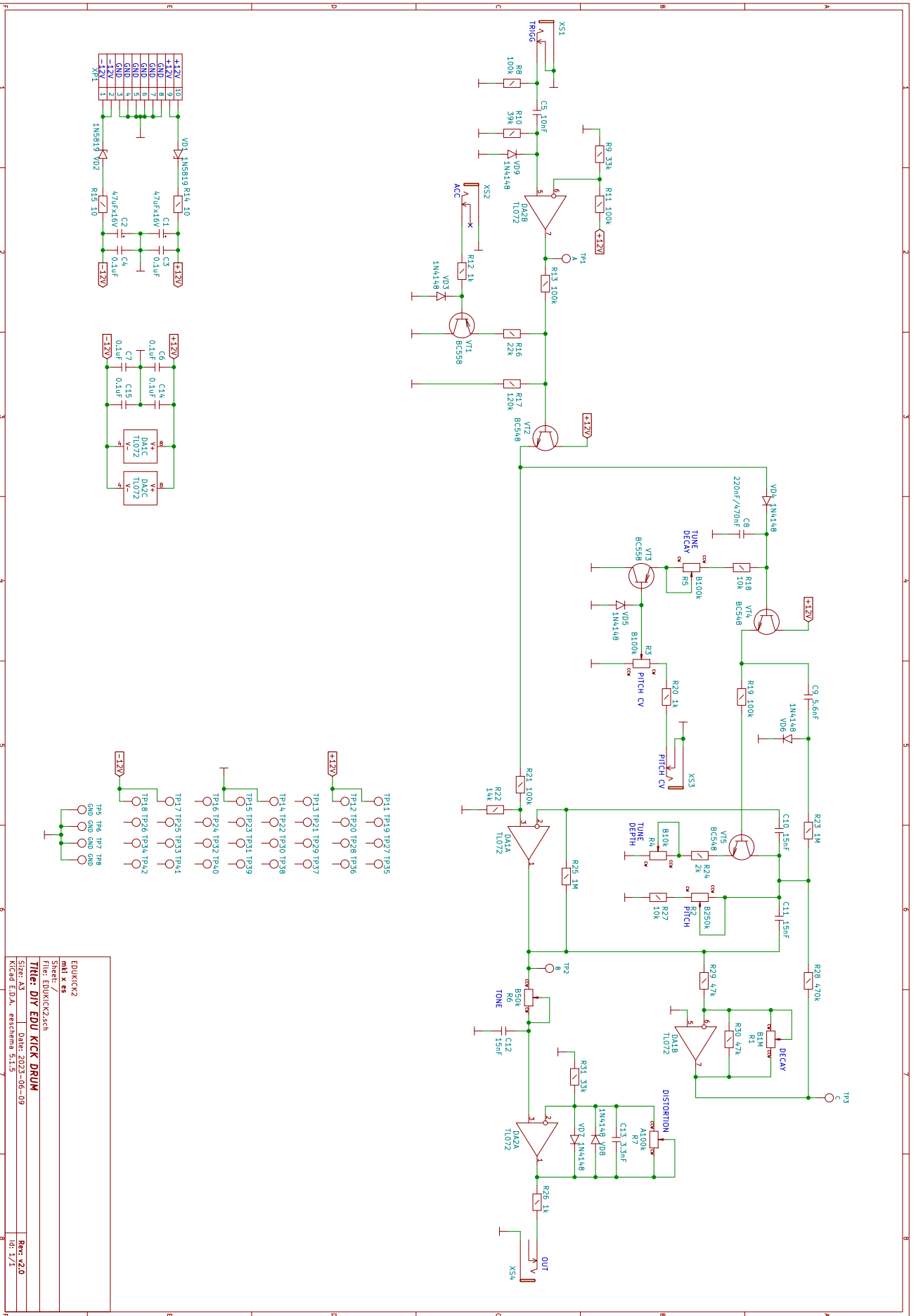

EDUICKC2	Sheet: /
mki x es	File: EDUICKC2.kch
	TRIE: DIY EDU KICK DRUM
Size: A3	Date: 2023-06-09
KiCad E.D.A. - schematics 5.1.5	Rev: v2.0
	Id: 1/1

Slow fuse protection

The 10 ohm resistors (**R14/R15**) serve another purpose: they act like slow fuses in case there's an accidental short circuit somewhere on the PCB – or if you insert a chip backwards into a DIP socket. The resistors will get hot, begin smoking, and finally break the connection. Even though they aren't really fuses, just having them there as fuse substitutes is pretty useful – you'd rather lose a cent on a destroyed resistor than a few euros on destroyed chips, right?

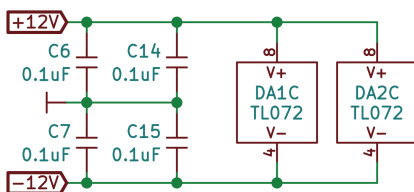

Additional decoupling

See the capacitors **C6**, **C7**, **C14**, **C15**? Those are additional decoupling capacitors. On the PCB, you'll notice that each of them is placed as close as possible to a chip's power pins – that's exactly where they're most effective. On well-designed PCBs, you'll usually find small decoupling capacitors next to every chip.

Just like the other decoupling caps discussed above, their job is to keep the supply voltage at each chip stable. When the voltage dips, they release stored charge to bridge the gap; when it spikes, they absorb the excess energy before it reaches the IC. We typically use 0.1 µF capacitors for this purpose.

PNP protection

On the breadboard, we've simply exposed our PNP transistors' bases to the outside world without any safety measures. In a real-life situation, a user might connect very negative voltages here. To protect the transistors in such a scenario, we've added a resistor/diode combination (e.g. **R12/VD3**). If the input voltage is very negative, the diode will conduct and hold the voltage steady just below 0 V.

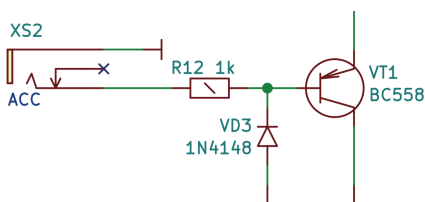

Output resistor

Finally, you'll notice a 1k resistor (**R26**) in series with the output (**XS4**). In a real-life situation, the user might connect this module to another via a long patch cable. Long patch cables have capacitance, which can make the output op amp ring or oscillate if driven directly. This resistor helps dampen that effect and keep the output stable.

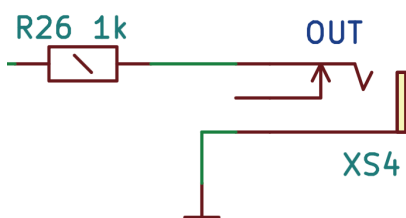

Module assembly

With this out of the way, let's start assembling your module. To help you figure out which component goes where, we've created a couple component placement diagrams. If any printed label on the PCB is hard to read or not clearly associated with a component slot, you can use these diagrams to double check.

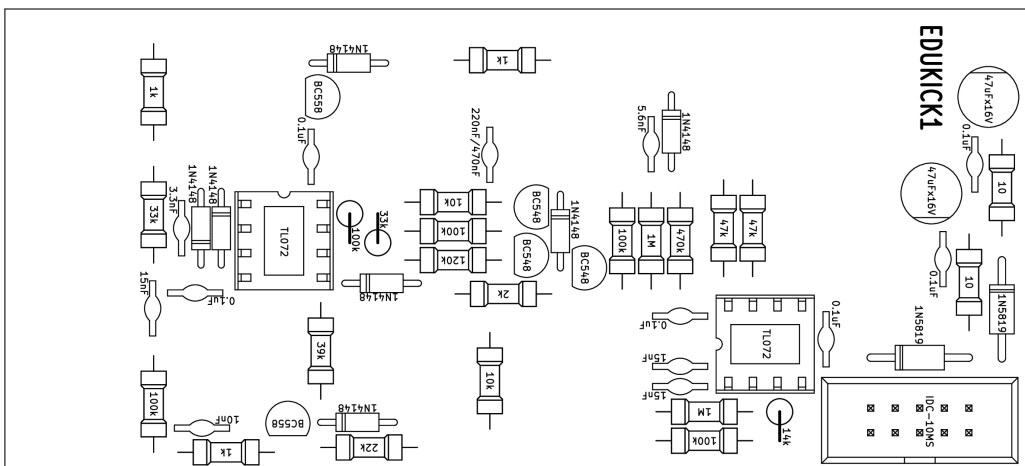
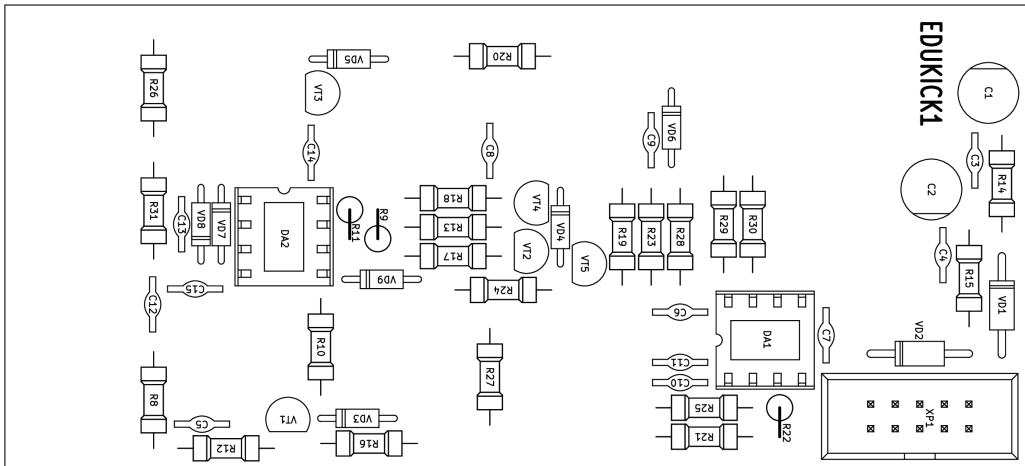
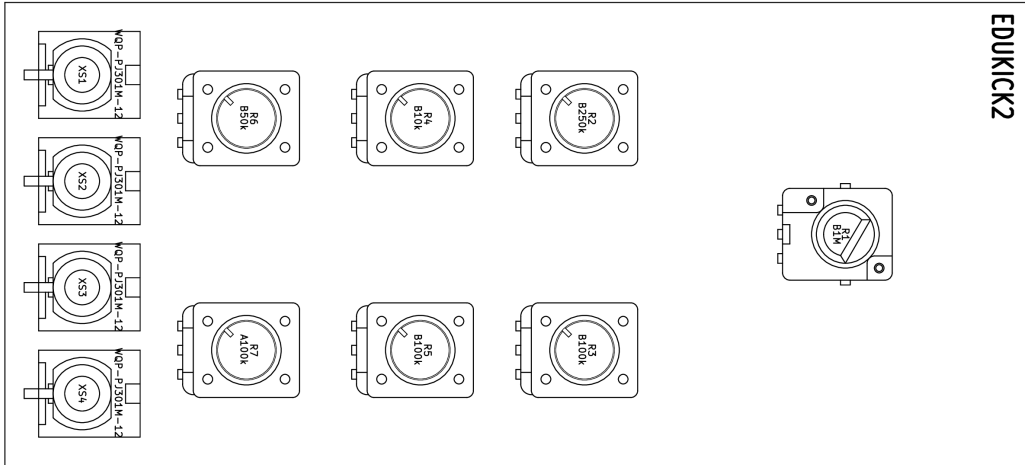

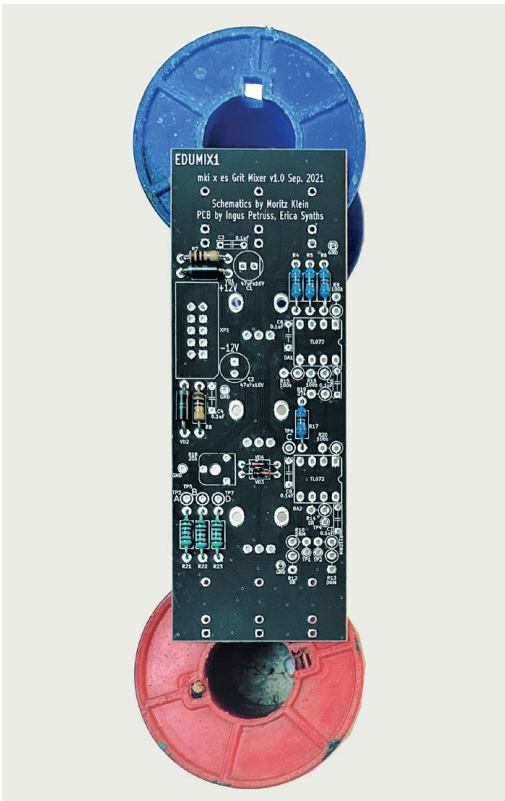

To start off: **place the kick drum PCB in a PCB holder or on spacers** (two empty solder wire spools work as well). If you don't have either, hold the PCB in one hand and insert components with the other.

Resistors and diodes

We will begin by populating the PCB with components that lay flat on the PCB. In this case, this is most of the resistors, switching diodes and the power protection diodes. Bend the resistor leads and insert them in the appropriate slots according to the part placement diagram on the previous page – or simply check the label and value indications printed onto the silkscreen. A multimeter helps to identify resistor values if you are unsure how to read the colored rings. **To fix a component in place, you can bend its leads against the back of the PCB.**

Next, insert the diodes. Be aware that orientation is critical here – the thick white stripe on the PCB indicates the cathode of a diode. **Align it with the stripe on the component.**

Flip the PCB over and apply solder to all populated holes. Then, use pliers to cut off the excess leads. (If you're having trouble with cold solder joints, you can try cutting the excess leads *before* soldering!)

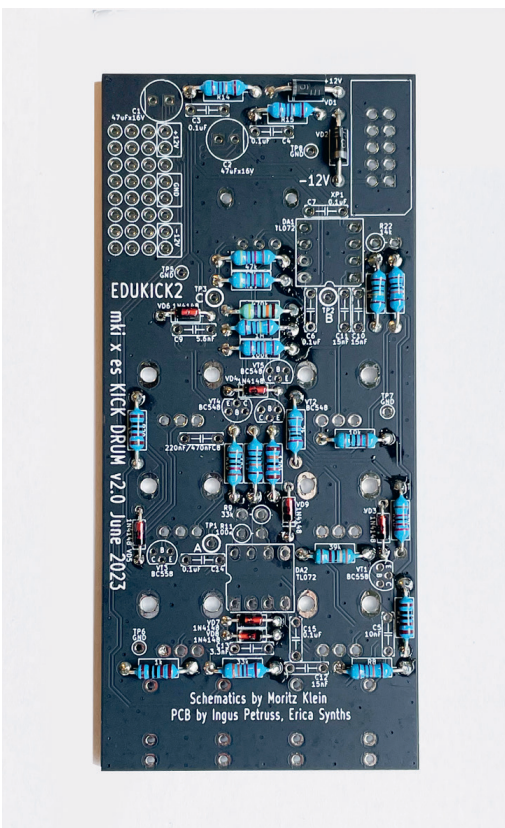

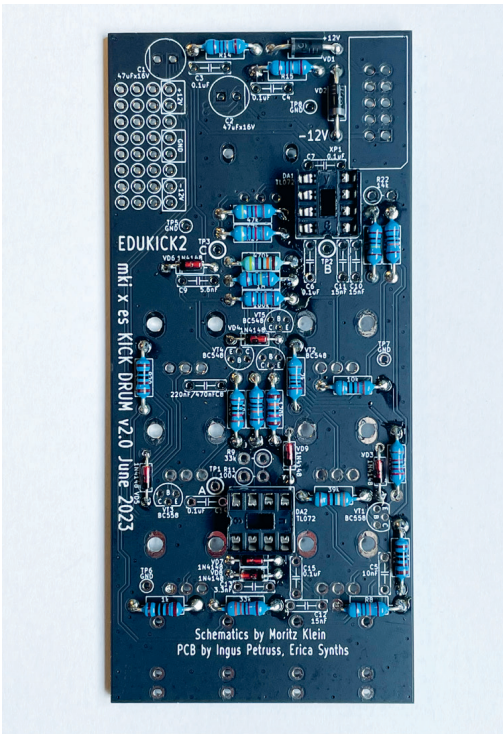

Chip sockets

Okay, let's move on to the chip sockets. Insert the first socket into its designated slot. Make sure it's oriented correctly – **the socket's notch should match the printed outline's notch on the PCB**. Apply a little bit of solder to the tip of your soldering iron. **Hold the socket in place, flip the PCB over, and apply the solder from the tip of your iron to one of the pins**. This should fix the socket in place, allowing you to put the PCB down and continue soldering the remaining pins. Repeat the same process with the other socket. **Do not insert the chips into their sockets yet** – they are sensitive to heat. Best to wait until all other components are soldered!

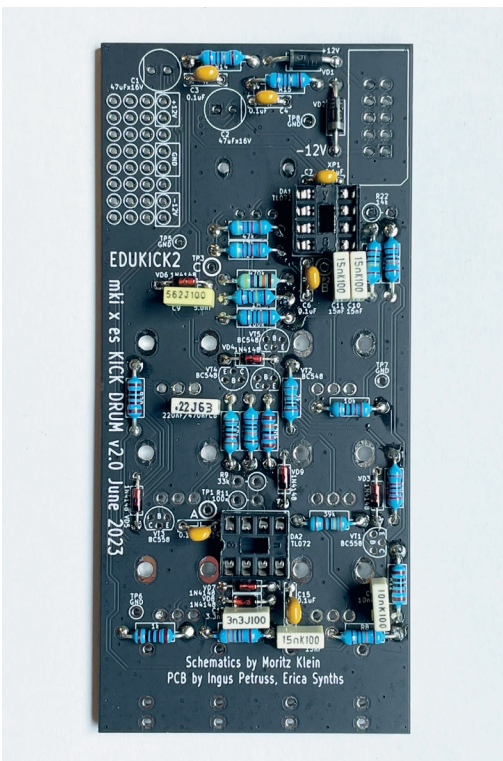

Ceramic and film capacitors

Next up: the ceramic and film capacitors. **These are non-polarized, so their orientation does not matter**. If you are unsure which capacitor type goes where, check the picture for reference. (In this module's case, all 0.1 μF capacitors are ceramic.)

Again, you can bend the leads against the back of the PCB to fix the components in place. Apply solder to all capacitor pins and trim the excess leads.

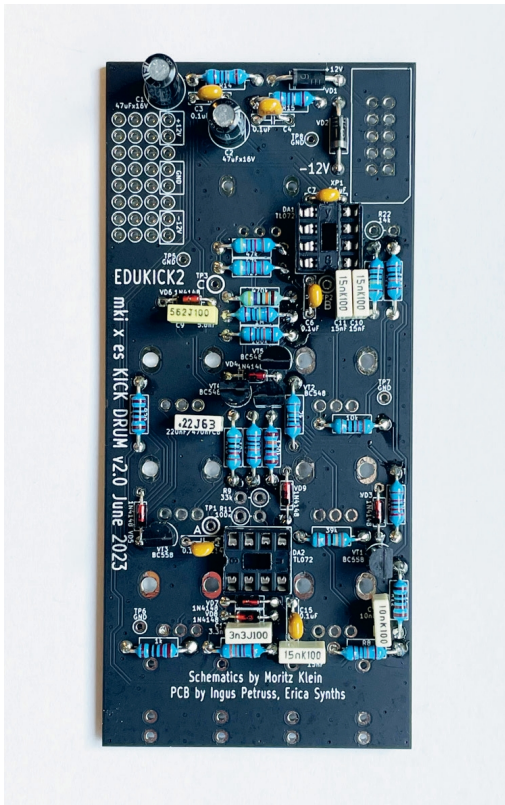

Transistors/electrolytic capacitors

Okay, let's tackle the transistors now. The circuit is using both **NPN (BC548/547)** and **PNP (BC558)** transistors. Since they look identical (except for the label printed onto the flat side of the black body), pay close attention to which type of transistor you insert into which slot. Also, orientation is important: make sure that the outline on the PCB matches the shape of the transistor. (The flat and round sides should line up!)

The holes for the transistors are significantly smaller than the other components' holes (and there's less space between them). Because of this, it's advisable to apply a little less solder than you did previously. You'll also want to trim the transistor's excess leads once done soldering.

Next, the electrolytic capacitors. **Electrolytic capacitors are polarized, so their orientation is important.** The longer leg marks the positive side, while the stripe on the body marks the negative one. On the PCB, the hole for the positive side has a square shape, and the stripe in the printed outline should match the stripe on the capacitor's body. Bend the leads against the PCB to fix the component in place, then solder & trim the leads.





Vertical resistors

Since space on the PCB is a little tight, some resistors need to be installed standing upright. Maybe you've spotted those slots already: two holes directly next to each other, with a big white circle around one of them. **The idea here is to only bend one of the resistor's legs until it looks like shown in the picture on the left.** Next, insert it into the slot with the body of the resistor aligning with the white circle on the PCB. You can then either solder the bent lead from the top to fix the resistor in place (like shown in the picture on the left), or bend the leads against the PCB from the other side again. After this, the procedure is the same as with the other resistors.

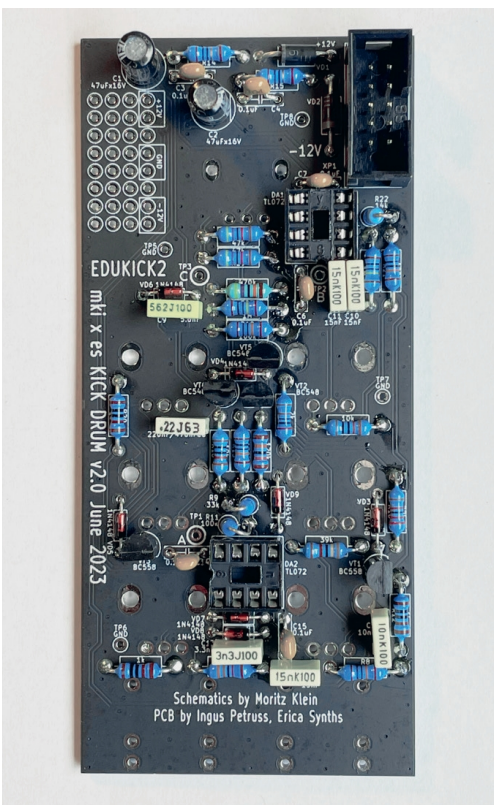
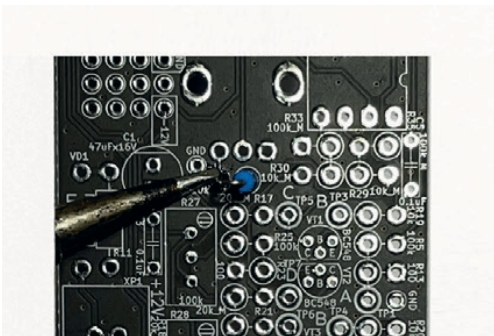

Power connector

Next, we'll complete the component side of the kick drum PCB by adding the 10-pin power supply header. Make sure the orientation of the header is as shown in the picture here: **the gap in the side of the plastic guide box should face outwards.** Apply some solder to your iron, turn the PCB around and fix one of the joints in place. Continue by soldering the remaining pins. After this, do a quick check to see if all components are soldered properly and there are no cold solder joints or accidental shorts. Clean the PCB to remove extra flux, if necessary.

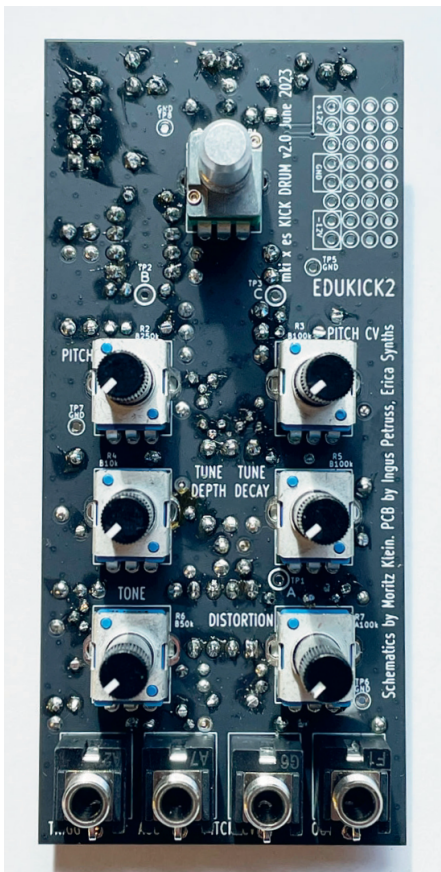

Potentiometers and jack sockets

Insert the metal potentiometer into the top slot, then add the six plastic shaft pots. **Make sure the potentiometer values match the value printed onto the PCB.** Be sure not to mix up the B100K and A100K potentiometers! Next, add the four jack sockets at the bottom. Don't solder any of these yet.



To ensure that all shafts align with the holes in the front panel and are able to move freely, you'll then want to fit the panel and secure it in place using the nuts of the metal potentiometer and jack sockets. Afterwards, flip the module over and solder both the potentiometers and jack sockets.

Be aware that the pots have two extra legs on either side that aren't used electrically, but should nevertheless be soldered for mechanical stability.

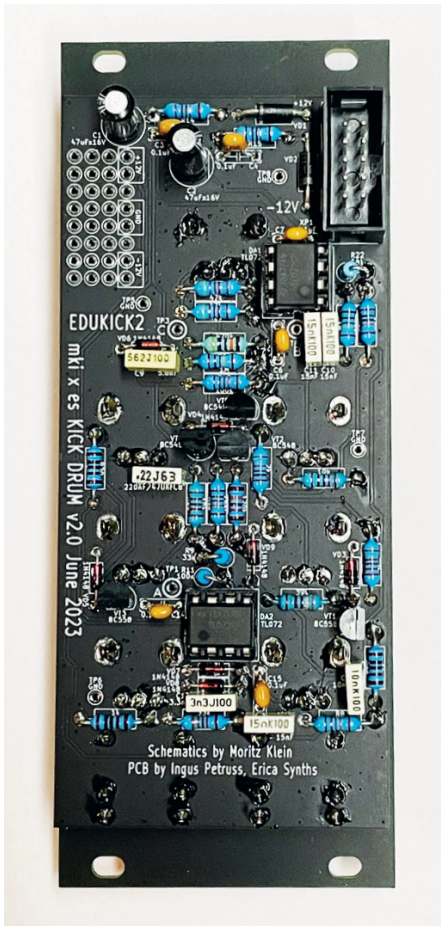

ICs and decay knob

Insert the ICs into their sockets, **aligning the notch on each chip with the notch on the socket**. Finally, unscrew the tiny screw in the side of the big knob cap, then turn the metal shaft potentiometer all the way to the left. Put the knob cap on top of the metal shaft and align the white stripe with the minimum decay setting. Tighten the screw. Done? Great – your kick drum module is complete!



Quick testing

Connect the module to a eurorack power supply (or use the LABOR Eurorack adapter expansion) and power it on. If there's no magic smoke, congratulations – your build was probably successful! The module requires no calibration.

To make sure everything works as expected, patch LABOR's **EG OUT** into the module's **TRIGGER** input, and connect your headphones to the **OUTPUT** socket. Press LABOR's **MANUAL GATE** button. You should hear a solid kick drum sound. If you do, great! Experiment with the different controls to create different tones. If not, no worries – we'll go through a bunch of troubleshooting steps next.

TROUBLESHOOTING APPENDIX

So your module is either completely dead, or certain controls don't work as expected? **Don't worry – this is extremely common, even for experienced builders.** In most cases, the issue comes down to a small soldering mistake or a component that's missing, misplaced, or inserted the wrong way around. To help you track this down systematically, we've exposed several test points on the PCB. By checking these one by one with your LABOR Scope (or any other oscilloscope), you can narrow the problem down to a specific part of the circuit instead of guessing.

Make sure to complete all of the troubleshooting steps in order. If a step's **parts to check** section mentions a component where orientation matters (diodes, transistors, ICs), verify both orientation and solder joints. For resistors and capacitors without polarity, checking the solder joints is usually sufficient.

Before you grab the scope

Before you start checking test points with LABOR Scope, double-check the following:

- All ICs are inserted into their sockets, oriented correctly, and fully seated.
- All diodes match the silkscreen orientation.
- The power header is oriented correctly.
- No obvious solder bridges between adjacent pads.
- No components missing according to the BOM.

These all look good? Then let's poke the circuit and see what we find.

TP1 (a)

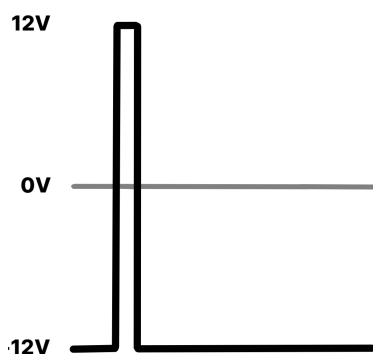

This test point exposes the **gate-to-trigger output**. Connect your LABOR Scope here using a long jumper cable, patch LABOR's **EG OUT** into the module's **TRIGGER** input, set LABOR's **TYPE** switch to the top position, and press the **MANUAL GATE** button. You should see a very brief voltage spike. Afterwards, the voltage should drop down to -12 V.

If you can't see anything, increase LABOR Scope's **TIME** setting to get a wider window of visibility. Be aware that you can sometimes get random double triggers that are unrelated to your build – LABOR's **MANUAL GATE** button is not debounced.

Behavior	Part(s) to check
Output stuck at 0 V	DA2
Output stuck at -12 V	C5, R9, VD9
Output stays high while button pressed	R10
Trigger on button release	VD9
Wide trigger on button press	R11

TP2 (b)

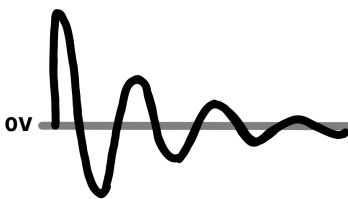

This test point exposes the **bridged-T oscillator's output**. Set the **DECAY** to 8 o'clock, the **PITCH** to 3 o'clock, and turn down **TUNE DEPTH** and **TUNE DECAY**. Connect your LABOR Scope to TP2 using a long jumper cable, set its **TIME** window to 100ms and its **RANGE** to 1V, then trigger the circuit. You should see a sine wave oscillation that quickly dies down.

Behavior	Part(s) to check
Output stuck at 0 V	VT2, DA1, R13
Output stuck at -12 V	R25
Constant square wave	C11
No oscillation, slightly elevated voltage	C10
Signal very loud, clipping	R22, R17, R30, R1

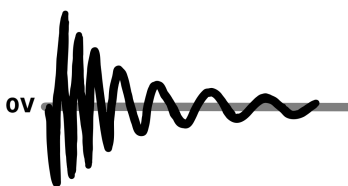
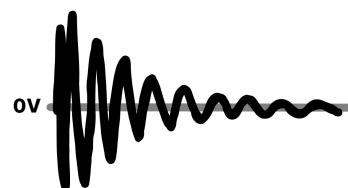

Next, set **PITCH** to varying levels and trigger the kick drum again. You should be able to change the oscillation frequency. If the frequency does not change at all, check **R2** and **R27**.

Then, turn both **TUNE DEPTH** and **TUNE DECAY** to 12 o'clock, turn **PITCH** way down, set the **DECAY** to 9 o'clock, increase LABOR Scope's **RANGE** to 2V, and trigger the kick drum again. The oscillation should get very fast at the beginning, then slow down.

Behavior	Part(s) to check
Oscillation frequency constantly slow	R24, R4, VT5, R19, VT5, VT4, VD4
Oscillation frequency only increases briefly	C8
Oscillation frequency stays fast and constant	R18, R5, VT3, R3

TP3 (c)

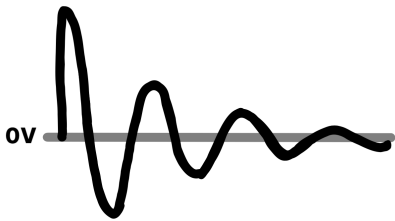

This test point exposes the **inverting feedback amp's output**. Keep the previous **DECAY** and **PITCH** settings, but turn down **TUNE DEPTH** and **TUNE DECAY**. Connect your LABOR Scope to **TP3** using a long jumper cable, set **TIME** to 100ms and **RANGE** to 1V, then trigger the circuit. You should see a sine wave oscillation that quickly dies down.

Behavior	Part(s) to check
Output stuck at 0 V	R29
Extremely loud square wave oscillation	R30, R1
Oscillation dies down almost instantly	R28



Next, turn the **DECAY** way up and trigger the circuit once. You should see a very long-lasting sine wave oscillation. If the **DECAY** setting does not affect the output at all, check **R1** again.

Output

To test the output signal, connect the **OUTPUT** to a mixer, interface, or a pair of headphones, turn the **DISTORTION** and **TONE** knobs down, the **DECAY** to about a quarter, and then trigger the circuit. You should hear a clean, clicky kick drum sound.

Behavior	Part(s) to check
No signal	R6, R26, XS4
Distorted sound with distortion at 0	R7
Extremely distorted sound	R7, VD7, VD8

Next, turn the **TONE** knob all the way up and trigger the circuit again. The kick should sound more mellow and less clicky. If nothing changes, check **C12**.

Then, turn **TONE** down, **DISTORTION** way up, and trigger the circuit again. The kick should sound distorted.

Behavior	Part(s) to check
Sound just gets louder	VD7, VD8
Nothing changes	R31

Long decay settings

A quick note on very long decay settings: you'll notice that pressing the gate button multiple times in quick succession produces hits that don't all sound the same. Some will be louder, others more muted. This is expected. **It's caused by the circuit's pendulum-like behavior: if you excite it again while it's still swinging, you may either reinforce or counteract its current motion, depending on the timing.**

Pitch CV

To test voltage control for the kick's pitch, keep the setup from the **OUTPUT** test, but additionally connect LABOR's **SIGNAL OUT** to the **PITCH CV** input. Set LABOR's **RANGE** switch to the bottom position, turn the **FREQUENCY** way down, and set the **SHAPE** switch to the bottom position as well. On the kick module, turn **PITCH CV**, **TUNE DEPTH**, and **PITCH** half way up. Trigger the circuit repeatedly. The kick's pitch should change between triggers. If the pitch stays the same, check **XS3** and **R20**.

Accent CV

To test voltage control for the kick's accent level, keep the setup from the **PITCH CV** test, but connect LABOR's **SIGNAL OUT** to the **ACCENT CV** input. Trigger the circuit repeatedly. The kick's volume should change between triggers – from completely dead to very loud. If the volume stays the same, check **XS2**, **R12**, **R16**, and **VT1**.