

INTRO | mki x es(edu)

Hey there, thanks for buying this DIY kit! We – **Erica Synths** and **Moritz Klein** – have developed it with one specific goal in mind: teaching people with little to no prior experience how to design analog synthesizer circuits from scratch. So what you’ll find in the box is not simply meant to be soldered together and then disappear in your rack.

Instead, we want to take you through the circuit design process step by step, explaining every choice we’ve made and how it impacts the finished module. For that, we strongly suggest you follow along on a **breadboard**¹, which is a non-permanent circuit prototyping tool that allows you to experiment and play around with your components. To help you with this, we’ve included suggested breadboard layouts in select chapters.

In addition to this, you can also play around with most of the chapter’s circuits in a **circuit simulator** called CircuitJS. CircuitJS runs in your browser. You’ll find weblinks in the footnotes which will direct you to an instance that already has example circuits set up for you. We strongly encourage you to fiddle with the component values and general structure of those circuits to get a better understanding of the concepts we’re laying out.

Generally, this manual is intended to be read and worked through front to back, but there were a few things we felt should go into a dedicated appendix. These are general vignettes on electronic components & concepts, tools, and the process of putting the module together once you’re done experimenting. Don’t hesitate to check in there whenever you think you’re missing an important piece of information. Most importantly though: have fun!

TABLE OF CONTENTS

CIRCUIT SCHEMATIC	2
BILL OF MATERIALS	3
POWERING YOUR BREADBOARD	6
USAGE WITH MKI x ES LABOR	7
CIRCUIT DESIGN CLOSE-UP	9
COMPONENTS & CONCEPTS APPENDIX	26
TOOLS APPENDIX	39
MODULE ASSEMBLY APPENDIX	41
SOLDERING APPENDIX	55

¹ Note that there is no breadboard included in this kit! You will also need a pack of jumper wires and two 9 V batteries with clips. These things are cheap & easy to find in your local electronics shop. Alternatively, consider investing in **MKI x ES LABOR**, our circuit prototyping board.

THE mki x es(educ) SNARE DRUM

No drum machine is really complete without a punchy, snappy snare. Together with the kick, it creates the rhythmic backbone for most grooves.

So in my ongoing quest for creating a Roland-inspired modular drum machine, I knew I had to come up with a snare circuit that would complement the kick and hi-hat I've already designed. After a lot of fine tuning, here's what I landed on.

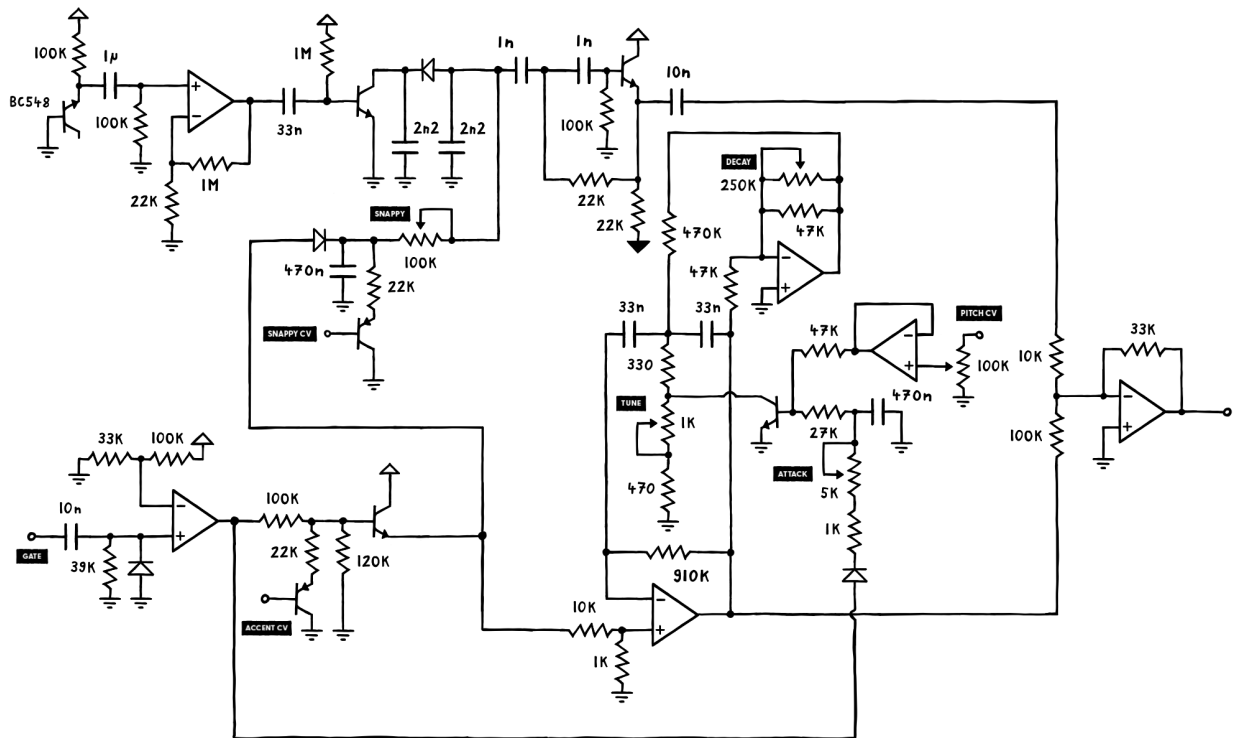

BILL OF MATERIALS

Before we start, please check if your kit contains all of the necessary components. In addition to a PCB, panel and power cable, your box should also contain:

An array of resistors. The specific values (in ohms, which you should check for with a multimeter) are

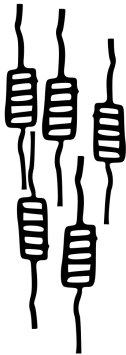

1M	x2
910k	x1
470k	x1
120k	x1
100k	x7
47k	x3
39k	x1
33k	x2
27k	x1
22k	x5
10k	x2
1k	x7
470	x1
330	x1
10Ω	x2

A bunch of capacitors. The specific values (which are printed onto their bodies) are

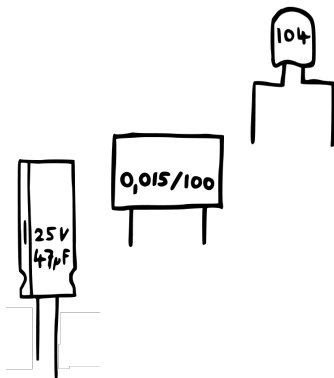

47 uF	x2
1 uF	x1
470 nF	x2
100 nF	x8
33 nF	x3
10 nF	x2
2.2 nF	x2
1 nF	x2

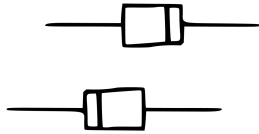

Some diodes. The specific model names (which are printed onto their bodies) are

1N4148 (signal) x6

1N5819 (schottky) x2

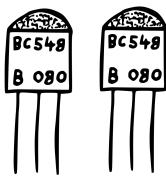

A couple of transistors. The specific model names (which are printed onto their bodies) are

BC558 (PNP) x2

BC548 (NPN) x5

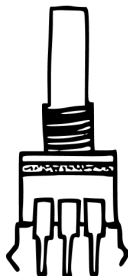

A handful of potentiometers. Their specific values (which may be encoded & printed onto their bodies) are

250k (B254) x1

100k (A104) x1

100k (B104) x1

5k (B502) x1

1k (B102) x1

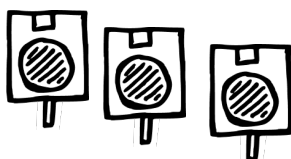

A few jack sockets. The specific models (which you can identify by their color) are

Switched mono (black) x5



A couple chips. Their specific models (which are printed onto their bodies) are

TL072 (dual op amp) x3

You will also find a few sockets that are only relevant when assembling the module in the end.

POWERING YOUR BREADBOARD

Before we can start building, you'll need to find a way of providing your breadboard with power. Ideally, you'd use a dual 12 V power supply for this. Dual power supplies are great – and if you want to get serious about synth design, you should invest in one at some point. But what if you're just starting out, and you'd like to use batteries instead? Thankfully, that's totally doable. **You just need to connect two 9 V batteries to your breadboard like shown here.**² For this, you should use 9 V battery clips, which are cheap & widely available in every electronics shop.

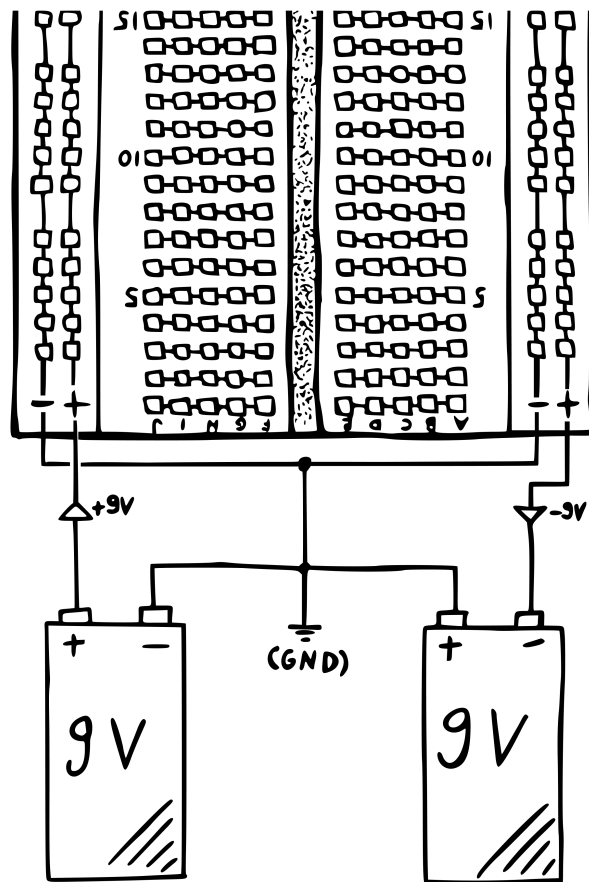

By connecting the batteries like this, the row on the left side labeled + becomes your positive rail, the row on the right side labeled + becomes your negative rail, and both rows labeled – become your ground rails.³

Please make sure you disconnect the batteries from your breadboard when you make changes to the circuit! Otherwise you run the risk of damaging components.

² Since the circuits in this manual were designed for a 12 V power supply, we assume that to be the default. Everything will still work roughly the same with 9 V, though.

³ This is a bit awkward because breadboards weren't really made with dual supply voltages in mind.

USAGE WITH MKI x ES LABOR

Alternatively, you can follow this guide using an **MKI x ES Labor** prototyping board. **Labor** comes equipped with everything you need for testing the circuits we lay out: a standard 830 tie point breadboard, an integrated dual power supply with over current protection, a manual gate/trigger/envelope generator, an LFO, a variable CV source, an output amplifier, and a modular interfacing section where you can insert all of your interfacing components like potentiometers, jack sockets, and switches.

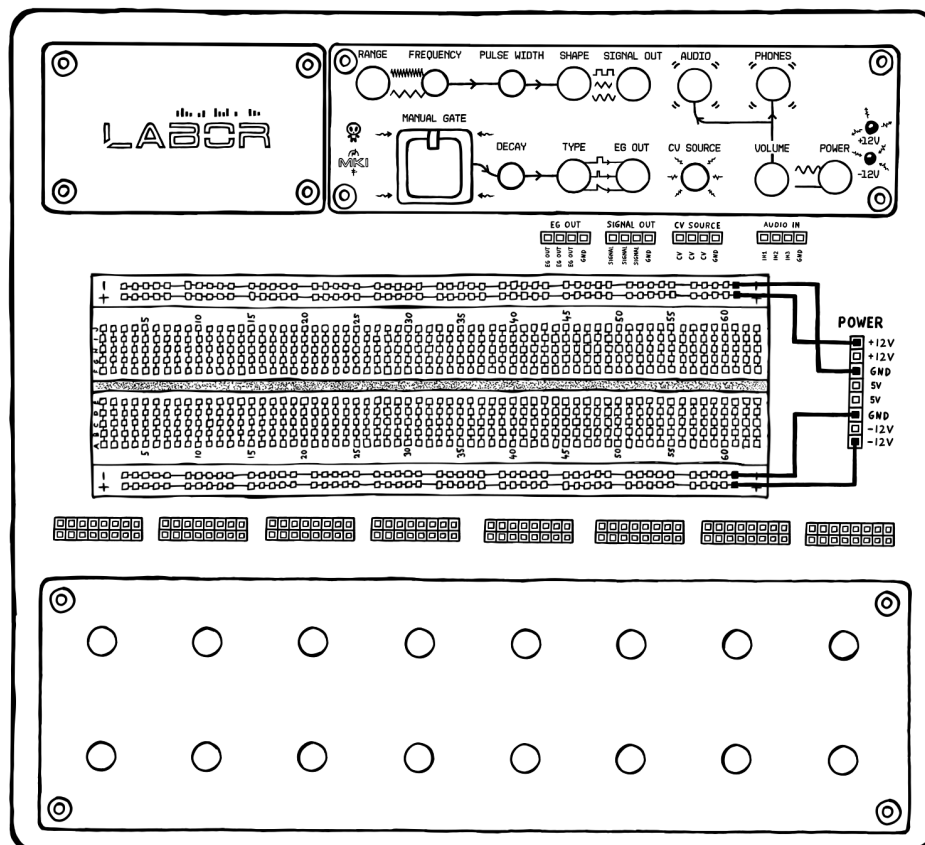

Before you get started, connect the slots labeled **GND** on the power header to both breadboard rails labeled - (minus). Next, connect one slot labeled **+12 V** to the top breadboard rail labeled + (plus), and one slot labeled **-12 V** to the bottom breadboard rail labeled + (plus). This way, the power rails match the setup of the suggested breadboard layouts in this manual.

Speaking of those suggested breadboard layouts: you'll notice that they prompt you to insert your interfacing elements directly into the breadboard, which can be finicky. When using **Labor**, you don't have to deal with this. Instead, plug those interfacing elements into the modular interfacing section at the bottom and connect them to the breadboard in the designated spots via the interfacing headers. You can read more about how this works in the **Labor** user manual.

To listen to your circuit, you don't even need to set up an output jack socket. Instead, use the built-in output amplifier at the top of the device. Just plug your circuit's signal output into the header labeled **AUDIO IN**, and then connect your headphones to the **PHONES** output jack (or a line-level device like a standalone external speaker to the **AUDIO** output jack).

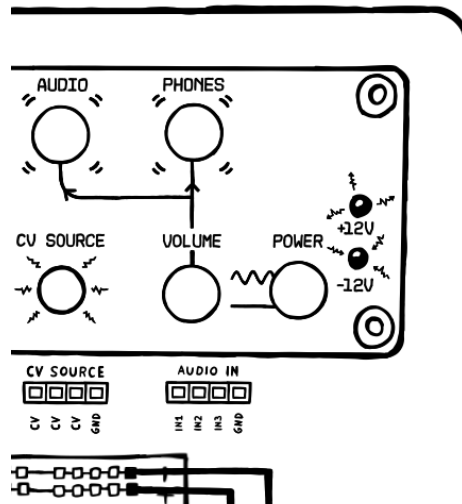

Sometimes, this guide will ask you to use external gear like sequencers or LFOs to send CV, audio signals, triggers or gates into your circuit. With **Labor**, there's no need for extra equipment – just use the built-in oscillator (audio/LFO), CV source or manual gate/trigger/envelope generator. You can grab all of those via the headers labeled **EG OUT**, **SIGNAL OUT**, and **CV SOURCE** and connect them to the designated points on the breadboard.

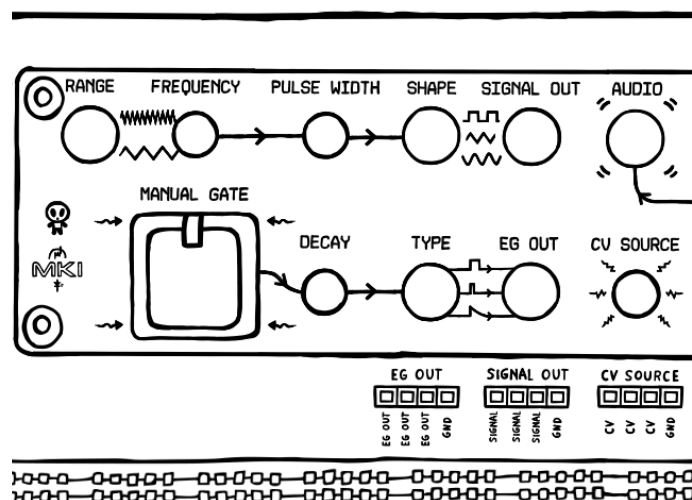

SNARE DRUM BASICS

As always when designing a drum voice, I'll start by mapping out the functional blocks we need for a classic analog snare. There are two main components to the sound: the drum (i.e. a pitched oscillation) and the snare wires (i.e. the noisy rattling).



We'll tackle the drum first. For that, we'll rely on the same percussive sine wave oscillator I used in my kick drum circuit. To give it a punchy attack, we'll then modulate its pitch with a simple envelope. For the snare wire sound, we'll start off with a standard white noise generator. Next, we'll use a VCA coupled with another envelope generator to shape the noise into a percussive burst.

Because that noise burst will be very bottom-heavy, we'll want to filter out a lot of the low end, so that the noise doesn't muddy up the drum sound later. For that, we'll add a rather aggressive high pass filter to the signal chain. Finally, we just need to mix the two signals together.

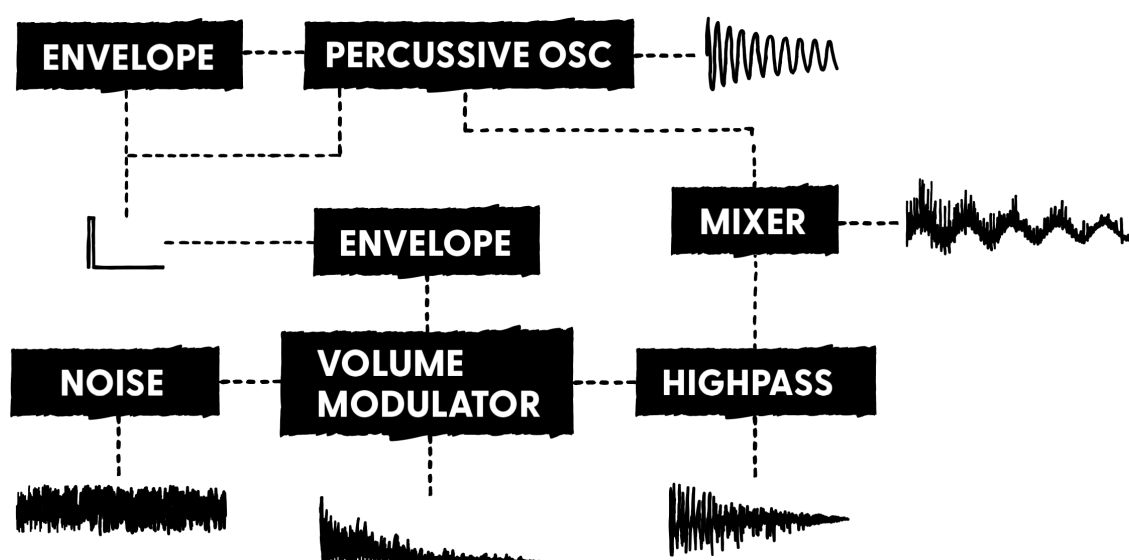

Alright, sounds like a plan – so let's try and implement this in an actual circuit. We'll start with the percussive oscillator.

DRUM OSCILLATOR

As I said before, we'll simply repurpose the oscillator I used in my kick drum for this. You can check that DIY kit's guide for an in-depth explanation, but here's the basic gist.

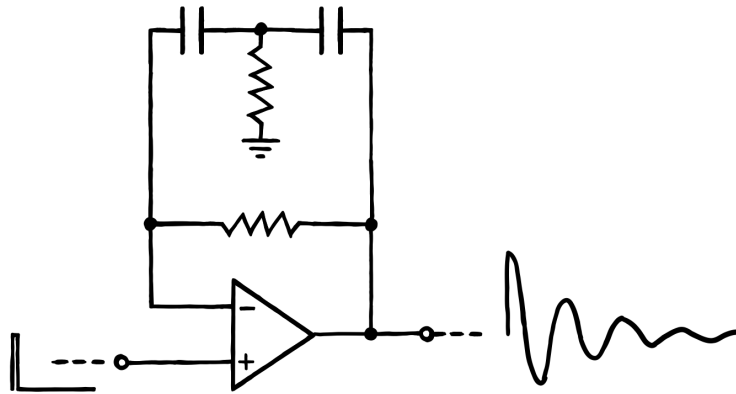

By plugging a bridged-t network consisting of two capacitors and two resistors into the feedback path of an op-amp, we create a highly resonant filter. If we then excite or „ping“ this filter with a quick voltage pulse, it'll oscillate for a little bit before eventually settling down.⁴ **That's why I called this a percussive oscillator: it creates a pitched, percussive hit all by itself, without the need for a VCA and an envelope generator.** Great! Now, to set the oscillation frequency, we'll have to pick specific values for the resistors and capacitors. For a snare, something in the 100 Hz – 200 Hz range should work fine.

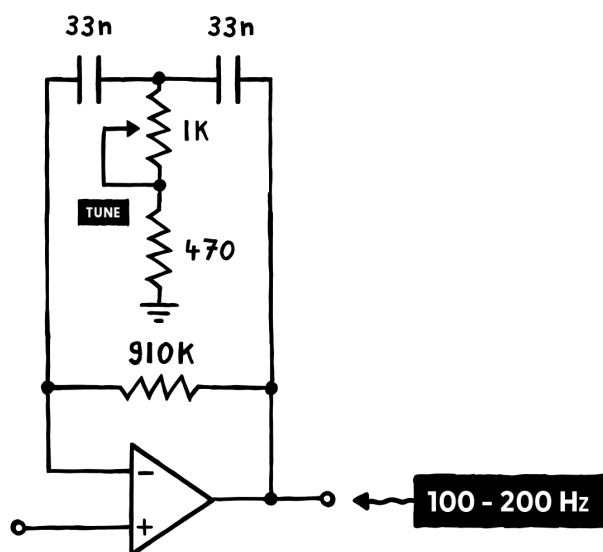

⁴ You can try this chapter's circuits in a simulator. I've already set them up for you right [here](#). You can change all values by double clicking on components.

Using a 910k bridge resistor, two 33n capacitors and a 470 ohms resistor to ground combined with a 1k potentiometer should allow us to roughly cover that range. Now, to actually test this, we'll need a quick voltage pulse (also called a trigger). Thankfully, we can reuse the gate-to-trigger converter I've come up with for my kick drum for this. **You can find an in-depth explanation in that kit's guide, but essentially, the circuit takes a gate signal coming from a sequencer for example, transforms it into a quick voltage pulse, and then allows you to cap that voltage pulse's height to a given control voltage via the accent CV in.**

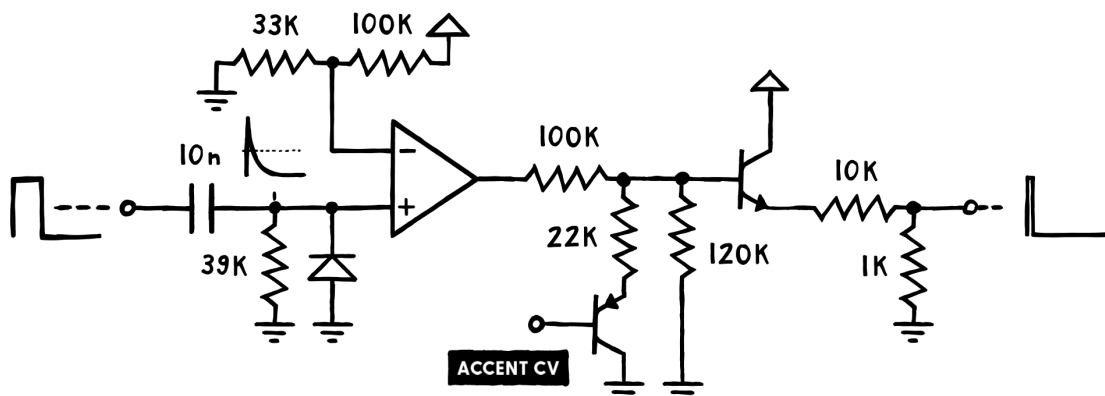

Since even the accented pulse is too hot for our oscillator and would cause it to distort, we'll scale it down using a simple 10k/1k voltage divider.

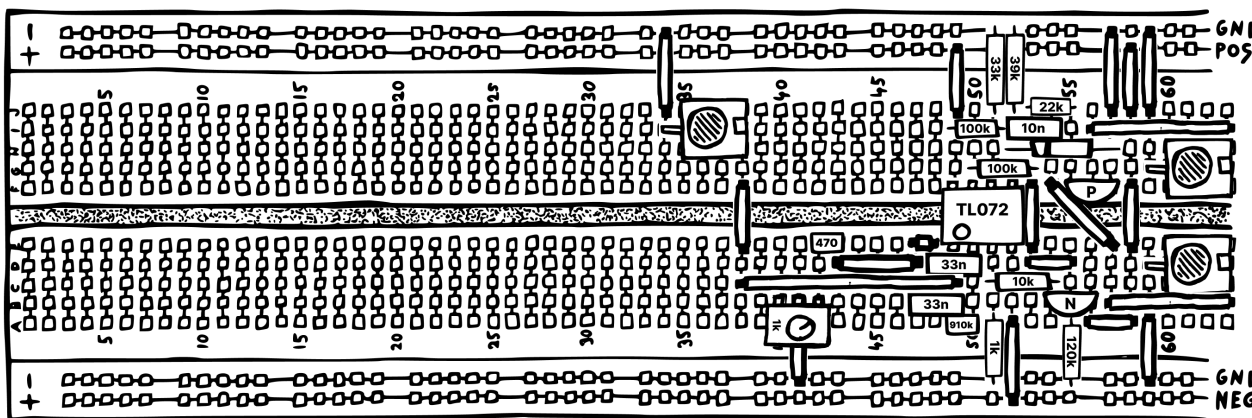

If you now apply a gate signal to the gate input (bottom right jack socket), you should get a short blip every time that gate hits. Then, you can tune it using the potentiometer. Also, you can vary the output volume via the accent CV input. Great! Depending on your use case, you might want extend the decay of this a little, though.

For that, we'll borrow another idea from my kick drum circuit: **forcing the oscillation to keep going for longer by applying positive feedback to the system.** And we do that with an op amp set up as an inverting amplifier with variable gain.

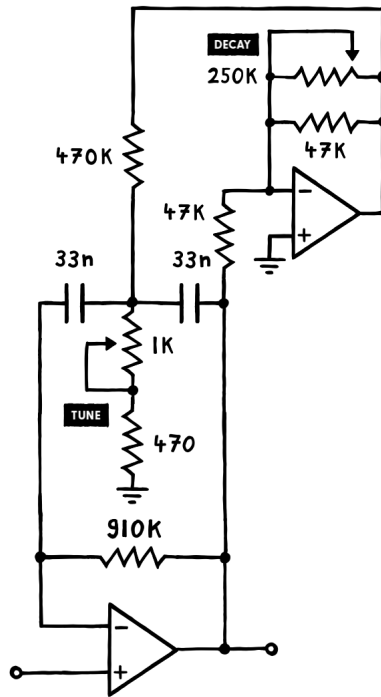

By using a 250k potentiometer in parallel with the 47k feedback resistor, we can dial in any amount of gain between 0 and about 0.8, which should give us a decently long tail on the drum sound.

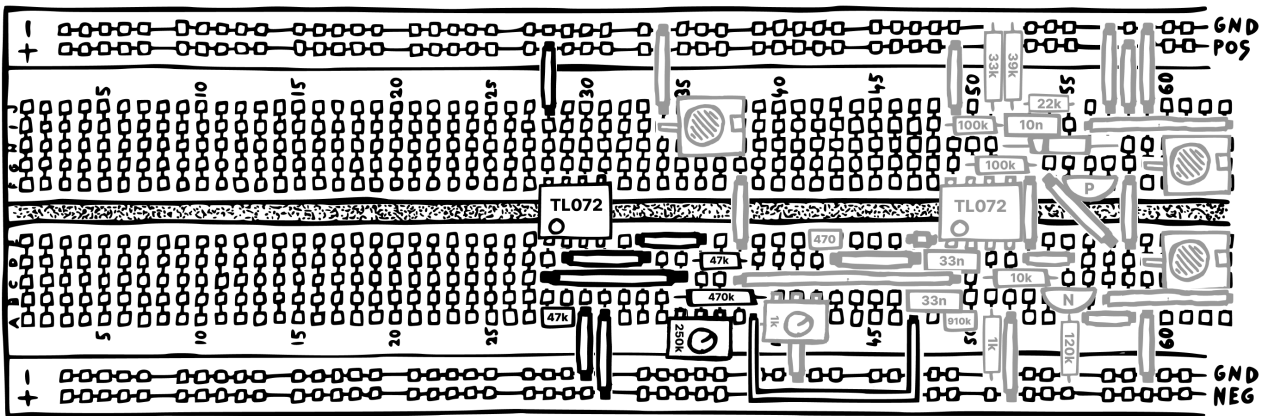

Try increasing the decay to the max – you should be able to get a much longer drum sound out of this.

ATTACK STAGE

Next, I want to add a punchy attack to the drum sound via a pitch envelope. For that, we'll take another cue from my kick drum circuit: bridging the resistance to ground in the oscillator with an NPN transistor.

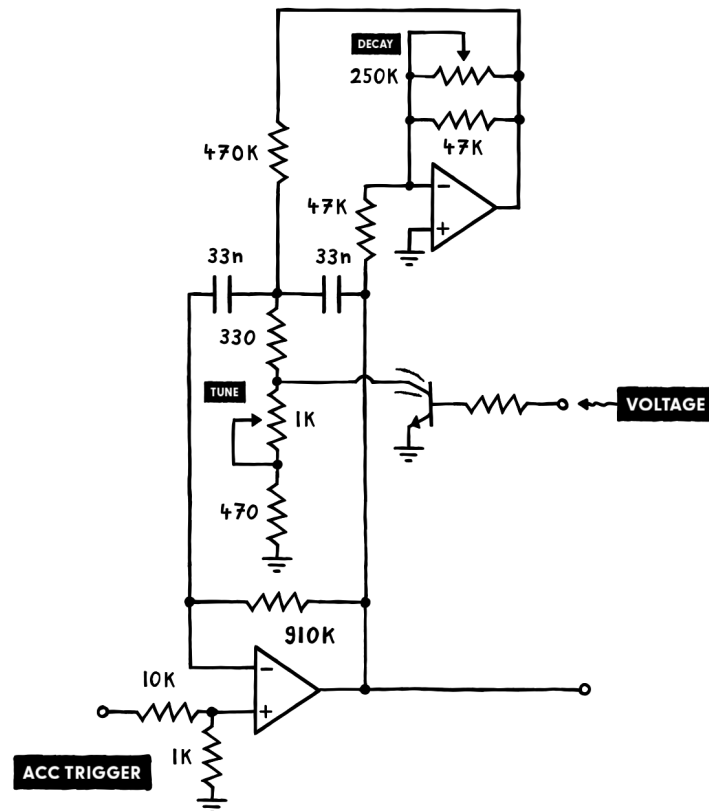

It works like this: if we apply a voltage to the transistor's base, it will allow current to bypass the potentiometer and 470Ω resistor, heavily reducing the effective resistance to ground and thereby increasing the oscillation frequency. To keep the pitch from going through the roof, we also add a small 330Ω series resistor – so the effective resistance doesn't drop straight to 0 when the transistor is fully open.⁵ This will also shift the pitch range downwards a bit – but I prefer lower pitched snares anyway, so I'm okay with that.

Next, we'll set up a simple envelope generator that'll control the transistor. It works like this: if we apply a trigger to the diode, current will flow into the capacitor, filling it up. (Since I want the attack to be consistent at different accent levels, we'll use the full size trigger instead of the accented one.)

⁵ You can try this chapter's circuits in a simulator. I've already set them up for you right [here](#). You can change all values by double clicking on components.

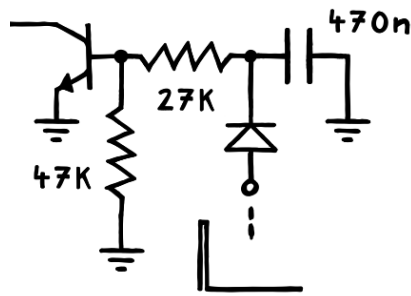

Then, when the trigger disappears, current slowly flows from the capacitor through the voltage divider, opening up the transistor in the process. Why do we need the voltage divider, though? Wouldn't a single bigger resistor connecting the cap and transistor have the same effect?

Not quite, since the transistor wouldn't allow the capacitor to fully discharge. That's because at voltages below 300-400 mV, barely any current is going to flow into the base. And this would prevent the oscillator from settling on its base pitch. **By introducing a dedicated path to ground, we fix this, allowing the cap to discharge steadily and completely.** Still, with this setup, the added punch would be a little too intense and dominant.

To deal with this, we'll insert a relatively small resistance after the input diode.

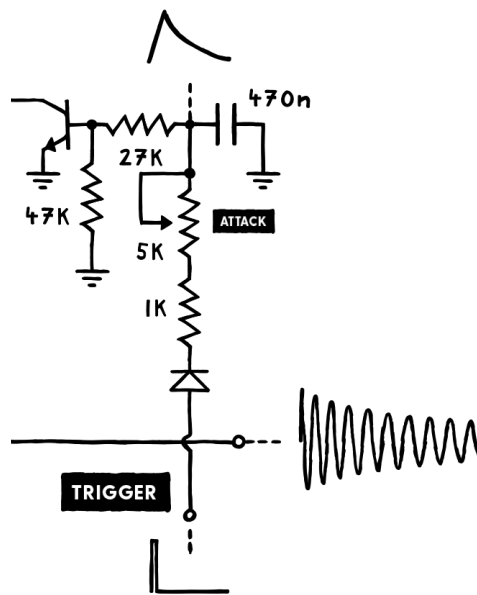

This way, charging the capacitor takes a bit longer (and it doesn't get charged up as much), which should result in a smoother, less intense attack. To be able to vary the effect, we combine a 1k resistor with a 5k potentiometer here.

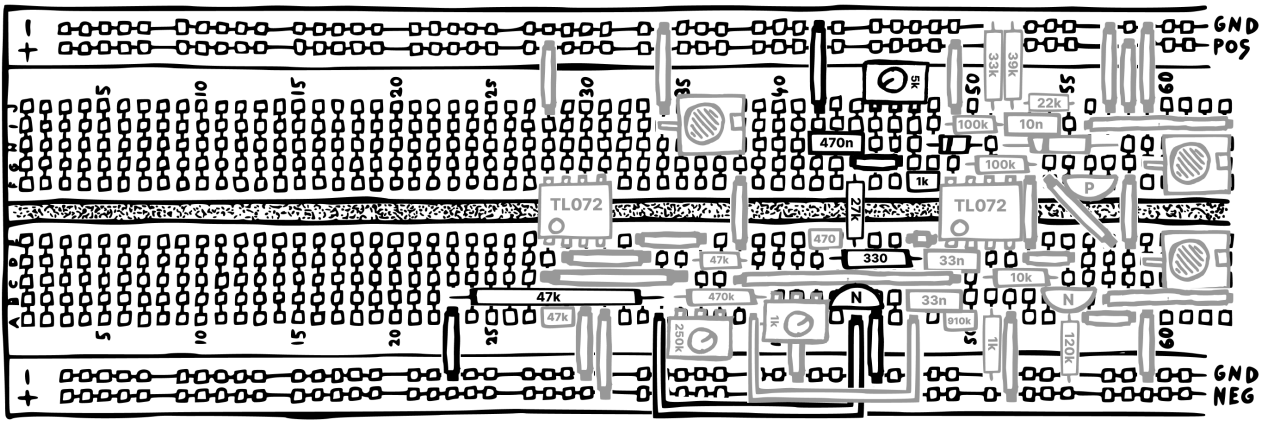

As expected, you should now be able to vary the attack's intensity from pretty punchy to really subtle. Great!

NOISE GENERATOR

Right now, our circuit sounds more like a 606-style tom than a snare. That's because we're missing the second main component of the sound: the snare wires. To implement it, we'll first need to set up a white noise generator. Here, we can again re-use part of a circuit I already designed. For my white, pink and blue noise generator module, I came up with this transistor-based white noise core.

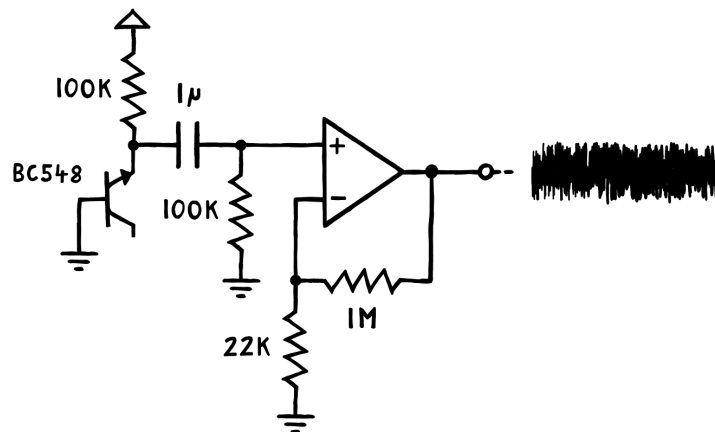

I recommend checking that kit's guide for an in-depth explanation, but here's a quick rundown. We wire up a transistor backwards, blasting its emitter with 12 V, which causes it to break down. **This allows for randomly fluctuating amounts of current to flow through the transistor, which causes the voltage below the resistor to fluctuate randomly as well.**⁶ The rest of the circuit is then simply processing the noise signal. We first center it around the 0 V line via AC coupling, and then we amplify it by a factor of 45, since the original signal is extremely low in volume.

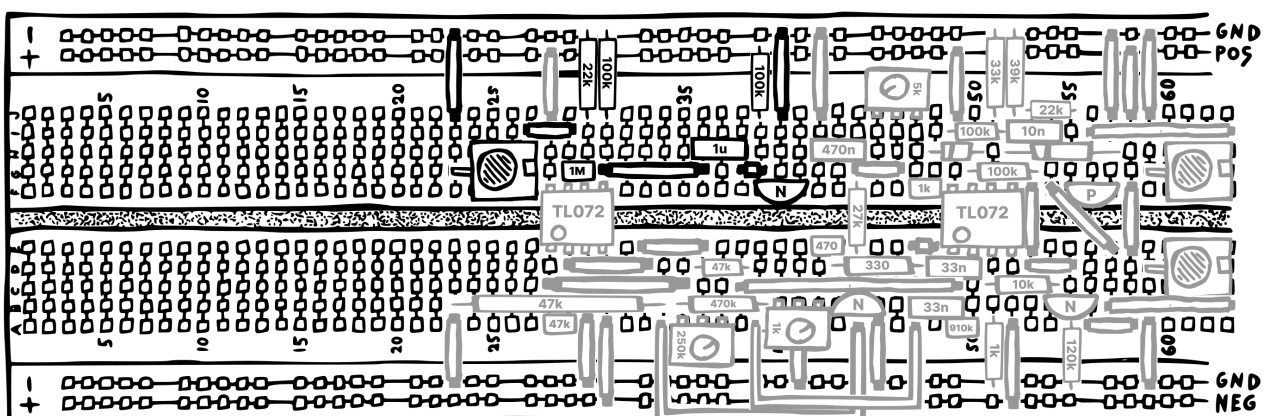

You should get a pretty uniform white noise signal out of the generator. Cool!

⁶ You can try this chapter's circuit in a simulator. I've already set it up for you right [here](#). You can change all values by double clicking on components.

To test this, you need to connect some sort of CV source to the VCA's CV input (e.g. a sequencer or an LFO). That CV should then control the volume of the noise signal at the output. Great!

NOISE ENVELOPE

With the VCA done, we'll now want to add another envelope generator, so we can make our noise match the volume contour of the drum sound.

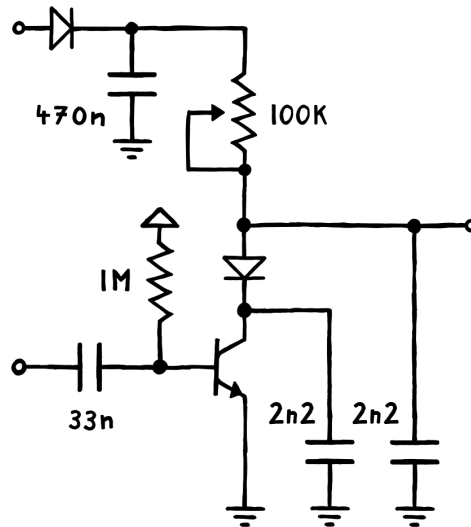

We'll deviate a little from the attack stage envelope design for this, though. First, we don't want the noise to come in gradually, but rather hit at full volume. So we'll omit the resistance between the diode and capacitor. And second, we'll want to control the speed with which the noise fades away to simulate tighter or looser snare wires. For that, we'll put a 100k potentiometer between the capacitor and the VCA's CV input.⁸

This way, that potentiometer is working double duty as the resistance that converts the current flowing through the VCA's transistor into a voltage – and as the discharging path for the envelope's capacitor.

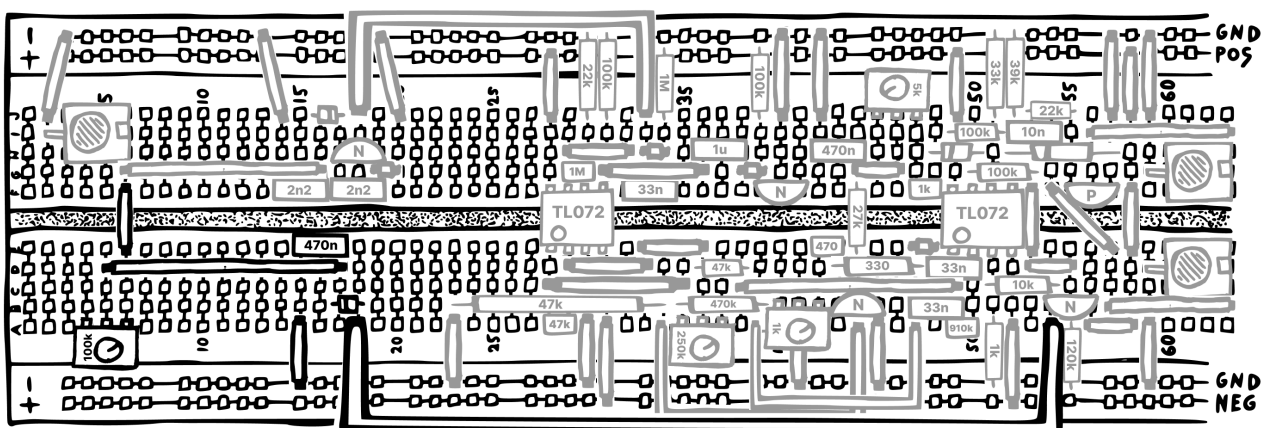

By turning the 100k potentiometer, you should be able to morph the constant noise into percussive bursts of varying lengths.

⁸ You can try this chapter's circuit in a simulator. I've already set it up for you right [here](#). You can change all values by double clicking on components.

HIGH PASS FILTER

Next, let's get rid of the noise's low end by routing it through an aggressive high pass. For that, we'll use a sallen-key high pass filter.

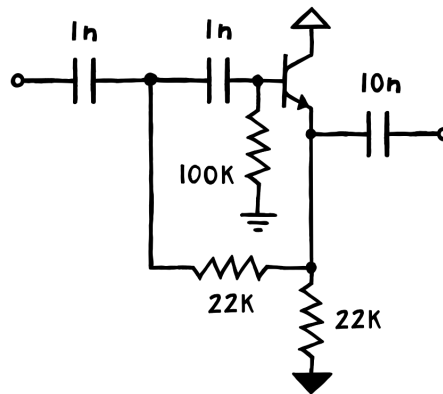

You might recognize this topology from our hi-hat circuit – though we used an op amp instead of a transistor as the active element there. Essentially, a sallen-key filter consists of two passive filter stages and an amplifier chained together. Then, the amplified output is routed back into the first filter stage.⁹

Adding the amplifier and the feedback does two things: first, it decouples the two filter stages, preventing them from loading each other down and thereby improving the filter's performance. And second, it allows us to introduce resonance. Here, the amount of resonance added depends on the size of the feedback resistor. As a rule of thumb, the smaller that resistor, the more resonance we'll get.

Using two 1 nF capacitors with a 100k resistor to ground and a 22k feedback resistor gives us a cutoff frequency of 3.4 kHz and a pronounced bump at that same frequency. For the amplifier, I'm using a simple NPN transistor set up as an emitter follower – with one slight catch. Since our noise signal is swinging around the 0 V-line, we need to give the transistor enough headroom to operate.

If we connect the resistor at the bottom to ground (like you normally would for an emitter follower), the transistor wouldn't be able to reproduce some of the signal because it's already fully closed at 0 V base voltage. So instead, we connect it to the negative rail. That way, the transistor has all the headroom it needs to amplify the full signal. The value of that resistor isn't super important, by the way – it will mostly influence the DC offset of the output, and also its volume.

A 22k resistor worked well for me here, giving us a roughly 3 V peak to peak output with an offset of about -1 V. To get rid of the latter, we simply AC couple the output using a 10 nF capacitor. (We can use such a small coupling cap here since the signal barely has any low end left anyway.)

⁹ You can try this chapter's circuit in a simulator. I've already set it up for you right [here](#). You can change all values by double clicking on components.

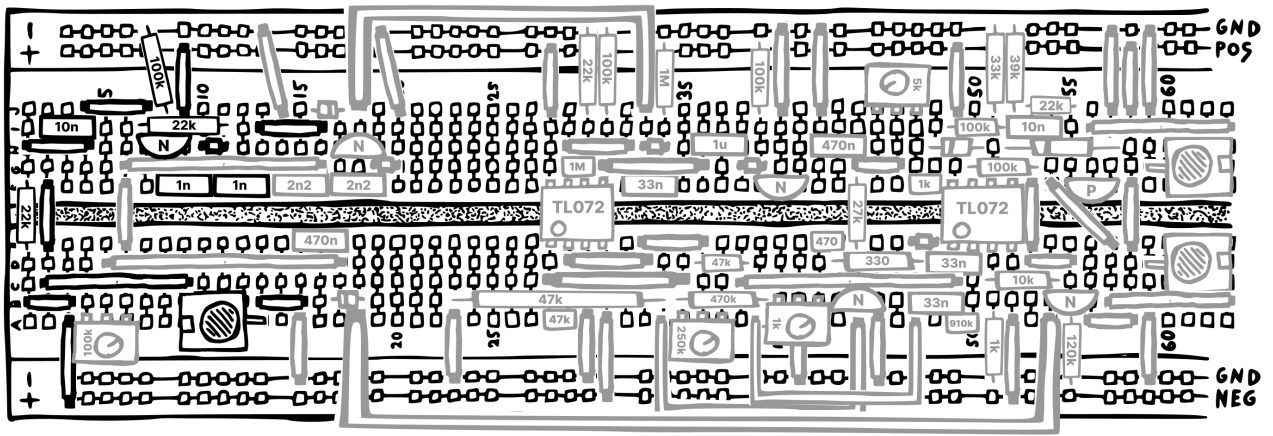

If you try this, the filter should remove a big chunk of the signal's low end – while also introducing a bit of bite via the added resonance.

PITCH CV

For the pitch CV input, there's a super simple solution: keeping the attack stage transistor open to varying degrees. Because remember: if that transistor is open, the oscillator's frequency increases. To open it, we can simply connect our control voltage to the 47k resistor at the transistor's base – instead of connecting it to ground.

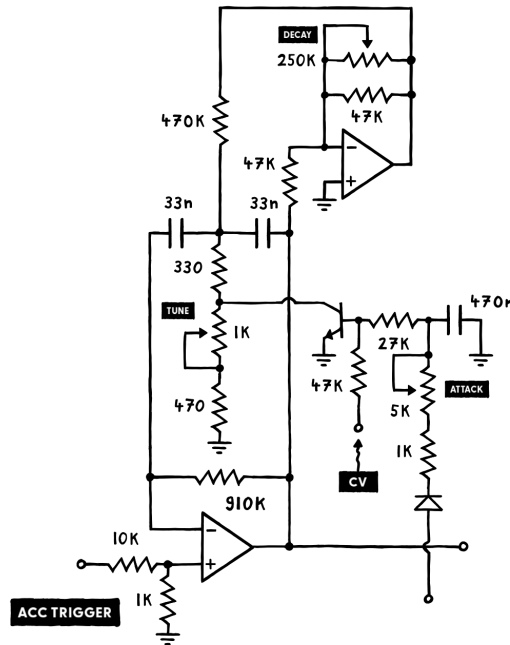

Then the oscillator's behavior will be unchanged at 0 V CV – but the pitch will increase as we push it up. Ideally, I'd also like to adjust the intensity with which the CV is affecting the pitch. To do that, you might be tempted to simply put a variable voltage divider between the CV input and the 47k resistor.

Unfortunately, this would mess with the capacitor's discharging process, slowing it down significantly. Which would in turn affect the sound of the attack. So we need to make sure that the impedance between the capacitor and ground stays the same. And we can achieve that by buffering the attenuated CV with a simple op-amp buffer. That way, the impedance between the transistor's base and the buffered CV is independent of the attenuation we apply.

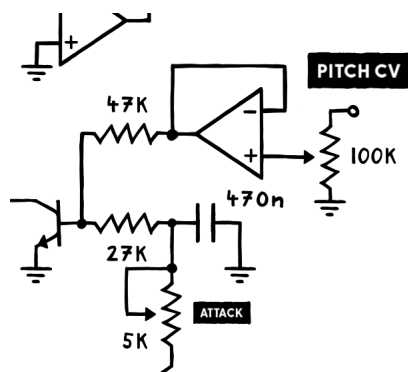

COMPONENTS & CONCEPTS

APPENDIX

In this section, we'll take a closer look at the components and elemental circuit design concepts we're using to build our module. Check these whenever the main manual moves a bit too fast for you!

THE BASICS:

RESISTANCE, VOLTAGE, CURRENT

There are three main properties we're interested in when talking about electronic circuits: **resistance, voltage and current**. To make these less abstract, we can use a common beginner's metaphor and compare the flow of electrons to the flow of water through a pipe.

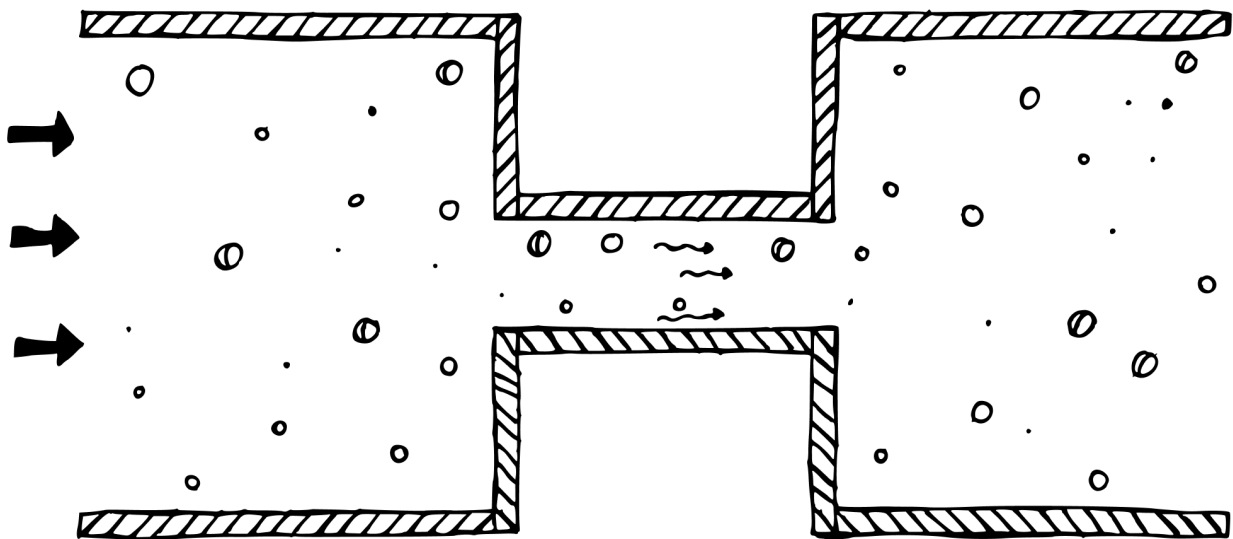

In that metaphor, resistance would be the width of a pipe. The wider it is, the more water can travel through it at once, and the easier it is to push a set amount from one end to the other. Current would then describe the flow, while voltage would describe the pressure pushing the water through the pipe. You can probably see how all three properties are interlinked: **more voltage increases the current, while more resistance to that voltage in turn decreases the current.**

USING TWO 9 V BATTERIES AS A DUAL POWER SUPPLY

Dual power supplies are great – and if you want to get serious about synth design, you should invest in one at some point. But what if you're just starting out, and you'd like to use batteries instead? Thankfully that's totally doable. **You just need to connect two 9 V batteries like shown here.** For this, you should use 9 V battery clips, which are cheap & widely available in every electronics shop.

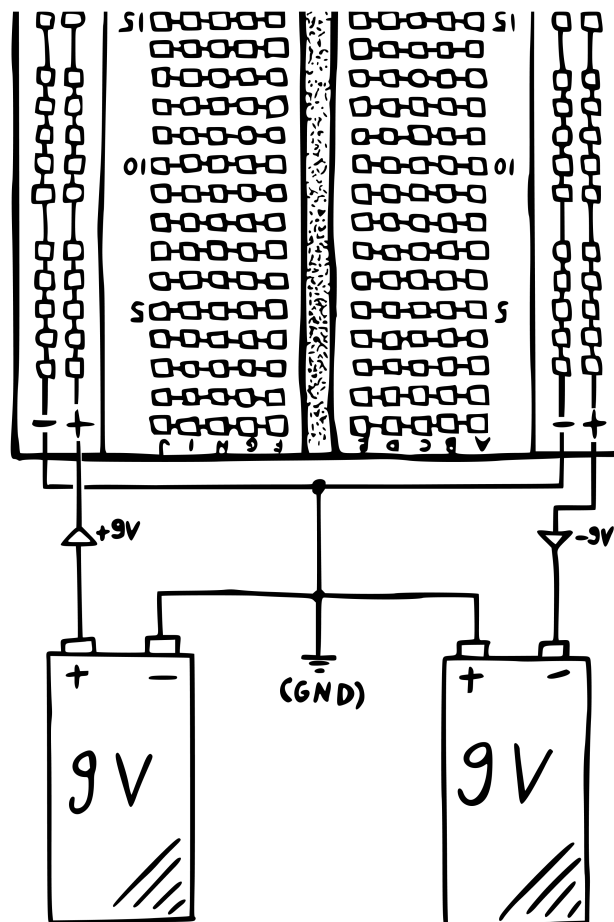

By connecting the batteries like this, the positive terminal of the left battery becomes your +9 V, while the negative terminal of the right is now your -9 V, and the other two combine to become your new ground.¹² **Please make sure you disconnect the batteries from your breadboard when you make changes to the circuit!** Otherwise you run the risk of damaging components.

¹² If you're struggling with setting this up, you can watch me do it [here](#).

RESISTORS

While a conductive wire is like a very big pipe where lots of water can pass through, a resistor is like a narrow pipe that restricts the amount of water that can flow. The narrowness of that pipe is equivalent to the resistance value, measured in ohms (Ω). The higher that value, the tighter the pipe.

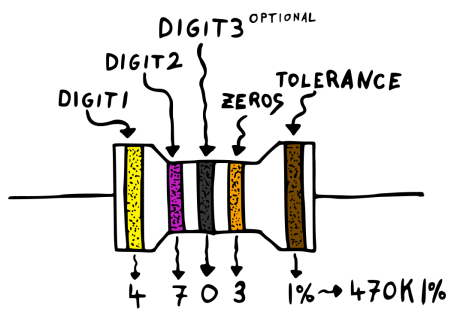
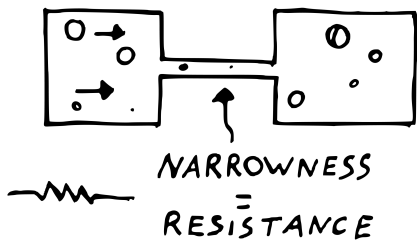

Resistors have two distinctive properties: linearity and symmetry. Linearity, in this context, means that for a doubling in voltage, the current flowing will double as well. Symmetry means that the direction of flow doesn't matter – resistors work the same either way.

On a real-life resistor, you'll notice that its value is not printed on the outside – like it is with other components. Instead, it is indicated by colored stripes¹³ – along with the resistor's tolerance rating. In addition to that, the resistor itself is also colored. Sometimes, depending on who made the resistor, this will be an additional tolerance indicator.

For the resistors in this kit, a yellow body tells you that the actual resistance value might be $\pm 5\%$ off. A dark blue body indicates $\pm 1\%$ tolerance. Some kits will also contain light blue $\pm 0.1\%$ resistors to avoid the need for manual resistor matching.

While in the long run, learning all these color codes will be quite helpful, you can also simply use a multimeter to determine a resistor's value.

¹³ For a detailed breakdown, look up [resistor color coding](#). There are also calculation tools available.

CAPACITORS

A capacitor is a bit like a balloon that you can attach to the open end of a pipe. If there's some pressure in the pipe, the balloon will fill up with water until the pressure equalizes. (Since the balloon needs some space to expand into, both of the capacitor's legs need to be connected to points in your circuit.)

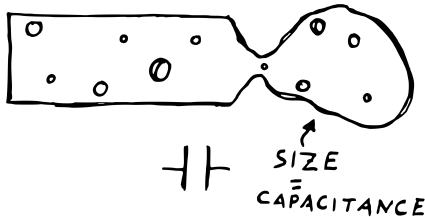

Then, should the pressure in the pipe drop, the balloon releases the water it stored into the pipe. The maximum size of the balloon is determined by the capacitor's capacitance, which we measure in farad (F). There are quite a few different types of capacitors: electrolytic, foil, ceramic, tantalum etc. They all have their unique properties and ideal usage scenarios – but the most important distinction is if they are polarized or not.

You shouldn't use polarized capacitors against their polarization (applying a negative voltage to their positive terminal and vice versa) – so they're out for most audio-related uses like AC coupling, high- & low-pass filters etc.

Unlike resistors, capacitors have their capacitance value printed onto their casing, sometimes together with a maximum operating voltage. **Be extra careful here!** That voltage rating is important. Your capacitors can actually explode if you exceed it! So they should be able to withstand the maximum voltage used in your circuit. If they're rated higher – even better, since it will increase their lifespan. No worries though: the capacitors in this kit are carefully chosen to work properly in this circuit.

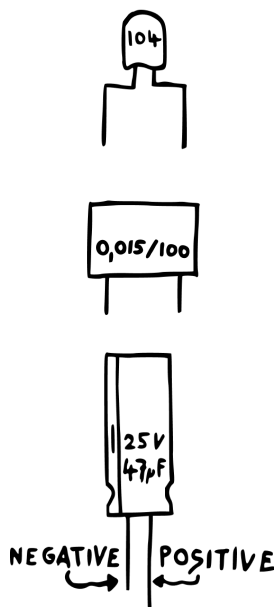

Ceramic capacitors usually come in disk- or pillow-like cases, are non-polarized and typically encode their capacitance value.¹⁴ Annoyingly, they rarely indicate their voltage rating – so you'll have to note it down when buying them.

Film capacitors come in rectangular, boxy cases, are non-polarized and sometimes, but not always, directly indicate their capacitance value and their voltage rating without any form of encoding.¹⁵

Electrolytic capacitors can be identified by their cylinder shape and silver top, and they usually directly indicate their capacitance value and their voltage rating. They are polarized – so make sure you put them into your circuit in the correct orientation.

¹⁴ For a detailed breakdown, look up [ceramic capacitor value code](#). There are also calculation tools available.

¹⁵ If yours do encode their values, same idea applies here – look up [film capacitor value code](#).

DIODES

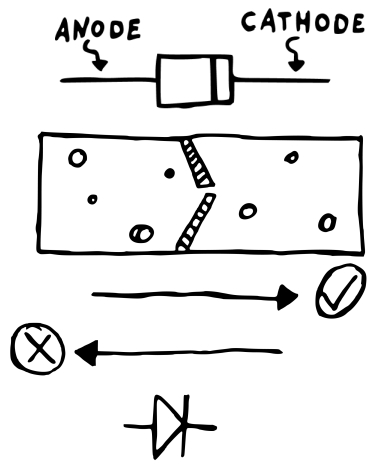

Diodes are basically like one-way valves. Current can only pass through in one direction – from anode to cathode. That direction is indicated by the arrow in the diode symbol and by a black stripe on the diode’s casing. So any current trying to move in the opposite direction is blocked from flowing.

There are a few quirks here, though. For one, the diode will only open up if the pushing force is strong enough. Generally, people say that’s 0.7 V, but in reality, it’s usually a bit lower. Also, diodes don’t open up abruptly – they start conducting even at much lower voltages, although just slightly.

There are a lot of different diode types: Zener, Schottky, rectifier, small signal etc. They all have their unique properties and ideal usage scenarios – but usually, a generic 1N4148 small signal diode will get the job done.

SCHMITT TRIGGER INVERTERS

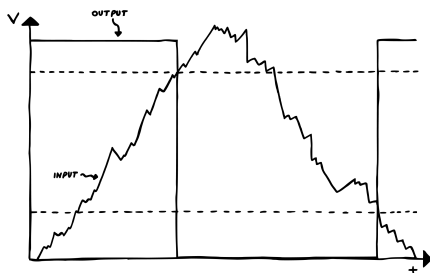
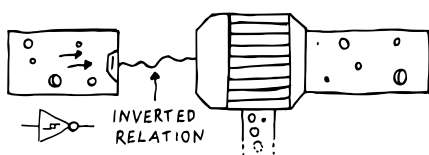

You can think of a Schmitt trigger inverter as two separate things. On the left, there’s a sensor that measures the pressure inside an attached pipe. On the right, there is a water pump. This pump’s operation is controlled by the sensor. Whenever the pressure probed by this sensor is below a certain threshold, the pump will be working. If the pressure is above a second threshold, the pump won’t be working. Here’s a quick graph to visualize that. The squiggly line represents the voltage at the input, while the dotted line shows the voltage at the output. So every time we cross the upper threshold on our way up, and the lower one on our way down, the output changes its state. One thing that’s very important to keep in mind: no current flows into the sensor! It’s really just sensing the voltage without affecting it.

VOLTAGE DIVIDERS

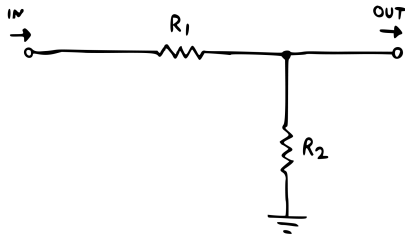

A voltage divider is really just two resistors set up like this: input on the left, output on the right. If R_1 and R_2 are of the same value, the output voltage will be half of what the input voltage is. How does it work?

Let's use our analogy again: so we have a pipe on the left, where water is being pushed to the right with a specific amount of force. Attached to it is a narrow pipe, representing R_1 , followed by another wide pipe. Then at the bottom, there's another narrow pipe, representing R_2 , where water can exit the pipe system. Finally, imagine we've set up a sensor measuring the voltage in the right hand pipe.

First, think about what would happen if R_2 was completely sealed off. Our sensor would tell us that **the pressure on the right side is exactly the same as the pressure on the left**. Because the pushing force has nowhere else to go.

On the other hand, imagine R_2 would just be a wide opening. Then **the pressure on the right would be 0**, because it'd all escape through that opening. But what happens if R_2 is neither completely closed off nor wide open? Then the pressure would be retained to varying degrees, depending on the narrowness of the two resistor paths.

If pipe R_1 is wide and pipe R_2 is narrow, most of the pressure will be retained. But if it's the reverse, the pressure level will be only a tiny fraction. And if R_1 and R_2 are identical, **the pressure will be exactly half of what we send in**.

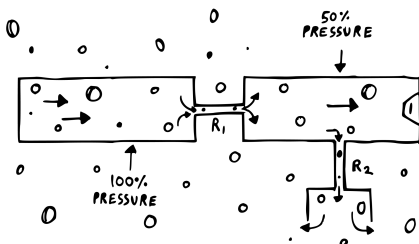
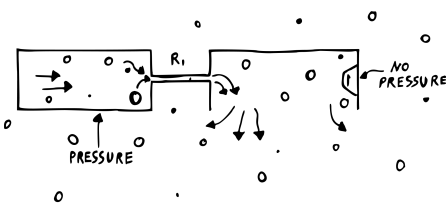
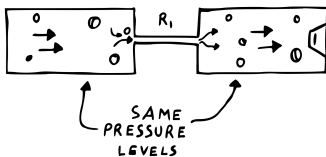

POTENTIOMETERS

Potentiometers can be used as variable resistors that you control by turning a knob. But, and that's the handy part, they can also be set up as variable voltage dividers. To see how that works, let's imagine we open one up.

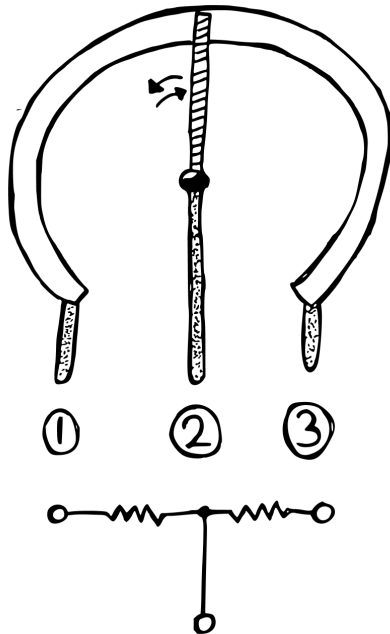

Inside, we would find two things: a round track of resistive material with connectors on both ends plus what's called a wiper. This wiper makes contact with the track and also has a connector. It can be moved to any position on the track. Now, the resistance value between the two track connectors is always going to stay exactly the same. That's why it's used to identify a potentiometer: as a 10k, 20k, 100k etc. But if you look at the resistance between either of those connectors and the wiper connector, you'll find that this is completely dependent on the wiper's position.

The logic here is really simple: **the closer the wiper is to a track connector, the lower the resistance is going to be between the two.** So if the wiper is dead in the middle, you'll have 50 % of the total resistance between each track connector and the wiper.

From here, you can move it in either direction and thereby shift the ratio between the two resistances to be whatever you want it to be. By now, you might be able to see how that relates to our voltage divider. If we send our input signal to connector 1 while grounding connector 3, we can pick up our output signal from the wiper. Then by turning the potentiometer's knob, we can adjust the voltage level from 0 to the input voltage – and anything in between.

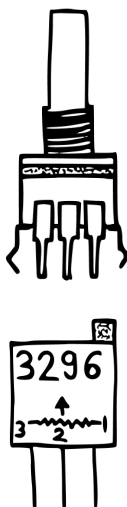

In these kits, you will encounter different types of potentiometers. First, there's the regular, full-size variant with a long shaft on top. These are used to implement user-facing controls on the module's panel and they usually – but not always – indicate their value directly on their casing. Sometimes, they'll use a similar encoding strategy as capacitors, though.¹⁶

Second, we've got the trimmer potentiometer, which is usually much smaller and doesn't sport a shaft on top. Instead, these have a small screw head which is supposed to be used for one-time set-and-forget calibrations. Trimmers usually encode their value.

¹⁶ Look up [potentiometer value code](#) for a detailed breakdown.

AC COUPLING

What is AC coupling – and how does it work? Imagine two adjacent pipes with a balloon between them. Now, no water can get from one pipe into the other, since it's blocked by the balloon. But, and that's the kicker, **water from one side can still push into the other by bending and stretching the balloon, causing a flow by displacement.**

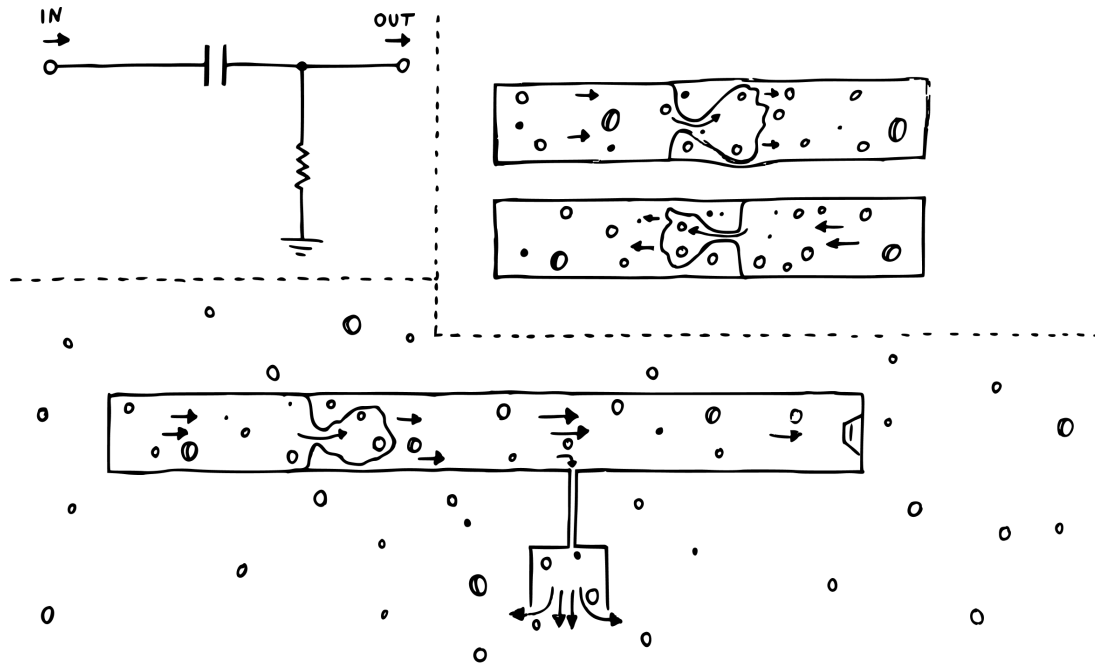

Next, we'll bring in a resistor after the coupling point, going straight to ground. **This acts like a kind of equalizing valve.** Now imagine we apply a steady 5 V from one side. Then on the other side, we'll read 0 V after a short amount of time. Why? Because we're pushing water into the balloon with a constant force, causing it to stretch into the other side, displacing some water. If we didn't have the equalizing valve there, we'd simply raise the pressure. But since we do have it, the excess water can drain out of the system. Until the pressure is neutralized, and no water is actively flowing anymore.

Okay, so now imagine that the voltage on the left hand side starts oscillating, let's say between 4 V and 6 V. When we start to go below 5 V, the balloon will begin contracting, basically pulling the water to the left. This will create a negative voltage level in the right hand pipe – like as if you're sucking on a straw, making the voltage there drop below 0 V. Then, once the pressure on the other side rises above 5 V, the balloon will inflate and stretch out again, pushing water to the right. And the pressure in the right hand pipe will go positive, making the voltage rise above 0 V. **We've re-centered our oscillation around the 0 V line.** Okay, but what about the resistor? If current can escape through it, doesn't that mess with our oscillation? Well, technically yes, but practically, we're choosing a narrow enough pipe to make the effect on quick pressure changes negligible!

OP AMPS

Op amps might seem intimidating at first, but they're actually quite easy to understand and use. The basic concept is this: every op amp has two inputs and one output. Think of those inputs like voltage sensors. You can attach them to any point in your circuit and they will detect the voltage there without interfering. **No current flows into the op amps inputs – that's why we say their input impedance is very high.** Near infinite, actually. Okay, but why are there two of them?

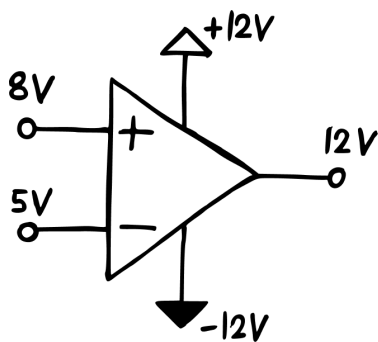

The key here is that op amps are essentially differential amplifiers. This means that they only amplify the difference between their two inputs – not each of them individually. If that sounds confusing, let's check out a quick example. So we'll imagine that one sensor – called the non-inverting input – is reading 8 V from somewhere. The other sensor – called the inverting input – reads 5 V. Then, as a first step, the op amp will subtract the inverting input's value from the non-inverting input's value. Leaving us with a result of 3. (Because 8 minus 5 is 3.) **This result then gets multiplied by a very large number – called the op amp's gain.** Finally, the op amp will try to push out a voltage that corresponds to that multiplication's result.

But of course, the op amp is limited here by the voltages that we supply it with. If we give it -12 V as a minimum and +12 V as a maximum, the highest it can go will be +12 V. So in our example, even though the result of that multiplication would be huge, the op amp will simply push out 12 V here and call it a day.

The handy thing though about op amp outputs is that they draw their power directly from the power source. This means that they can supply lots of current while keeping the voltage stable. **That's why we say an op amp has a very low output impedance.**

OP AMP BUFFERS/AMPLIFIERS

Buffering, in the world of electronics, means that we provide a perfect copy of a voltage without interfering with that voltage in the process. With an op amp-based buffer, the buffering process itself works like this. We use the non-inverting input to probe a voltage, while the inverting input connects straight to the op amp's output. **This creates what we call a negative feedback loop.** Think of it this way. We apply a specific voltage level to the non-inverting input – let's say 5 V.

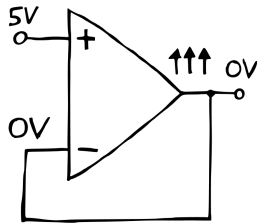

Before the op amp starts processing the voltages at its inputs, the output will be switched off. This means that **output and inverting input sit at 0 V at first.** So then, the op amp will subtract 0 from 5 and multiply the result by its gain. Finally, it will try and increase its output voltage to match the calculation's outcome.

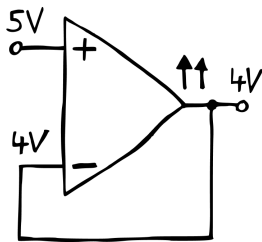

But as it's pushing up that output voltage, the **voltage at the inverting input will be raised simultaneously.** So the difference between the two inputs is shrinking down. Initially, this doesn't matter much because the gain is so large. As the voltage at the inverting input gets closer to 5 V though, the difference will shrink so much that in relation, the gain suddenly isn't so large anymore.

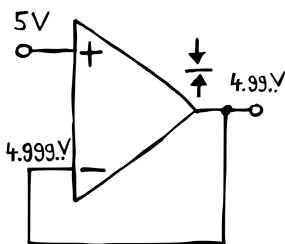

Then, the output will **stabilize at a voltage level that is a tiny bit below 5 V**, so that the difference between the two inputs multiplied by the huge gain gives us exactly that voltage slightly below 5 V. And this process simply loops forever, keeping everything stable through negative feedback. Now if the voltage at the non-inverting input changes, that feedback loop would ensure that the output voltage is always following. So that's why this configuration works as a buffer: the **output is simply following the input.**

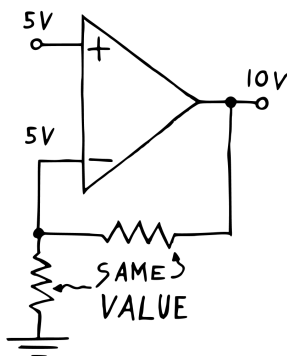

How about amplifying a signal though? To do that, we'll have to turn our buffer into a proper non-inverting amplifier. We can do that by replacing the straight connection between inverting input and output with a voltage divider, forcing the op amp to work harder. Here's how that works. Say we feed our non-inverting input a voltage of 5 V. Now, **the output needs to push out 10 V in order to get the voltage at the inverting input up to 5 V.** We call this setup a non-inverting

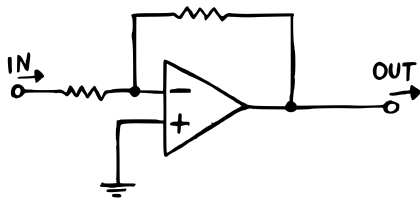

amplifier because the output signal is in phase with the input.

For an inverting buffer/amplifier, the input signal is no longer applied to the non-inverting input. Instead, that input is tied directly to ground. So it'll just sit at 0 V the entire time. The real action, then, is happening at the inverting input. Here, we first send in our waveform through a resistor. Then, the inverting input is connected to the op amp's output through another resistor of the same value.

How does this work? Well, let's assume that we're applying a steady voltage of 5 V on the left. Then, as we already know, the op amp will subtract the inverting input's voltage from the non-inverting input's voltage, leaving us with a result of -5 V. Multiply that by the huge internal gain, and the op amp will try to massively decrease the voltage at its output.

But as it's doing that, an increasingly larger current will flow through both resistors and into the output. Now, as long as the pushing voltage on the left is stronger than the pulling voltage on the right, some potential (e.g. a non-zero voltage) will remain at the inverting input. Once the output reaches about -5 V though, we'll enter a state of balance. Since both resistors are of the same value, the pushing force on the left is fighting the exact same resistance as the pulling force on the right. **So all of the current being pushed through one resistor is instantly being pulled through the other.**

And that means that the voltage at the inverting input will be lowered to about 0 V, allowing our op-amp to settle on the current output voltage level. So while we read 5 V on the left, we'll now read a stable -5 V at the op amp's output. Congrats – we've built an inverting buffer! **If we want to turn it into a proper amplifier, we'll simply have to change the relation between the two resistances.** By doing this, we can either increase (if you increase the right-hand resistor's value) or reduce (if you increase the left-hand resistor's value) the gain to our heart's content.

BIPOLAR JUNCTION TRANSISTORS

Bipolar junction transistors (or BJTs for short) come in two flavors: NPN and PNP. This refers to how the device is built internally and how it'll behave in a circuit. Apart from that, they look pretty much identical: a small black half-cylinder with three legs.

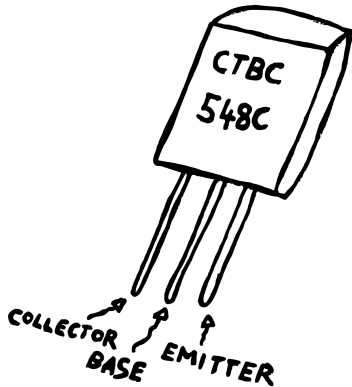

Let's take a look at the more commonly used NPN variant first. Here's how we distinguish between its three legs. **There's a collector, a base and an emitter.**¹⁷ All three serve a specific purpose, and the basic idea is that you control the current flow between collector and emitter by applying a small voltage¹⁸ to the base. The relation is simple: **more base voltage equals more collector current.** Drop it down to 0 V and the transistor will be completely closed off. Sounds simple – but there are four important quirks to this.

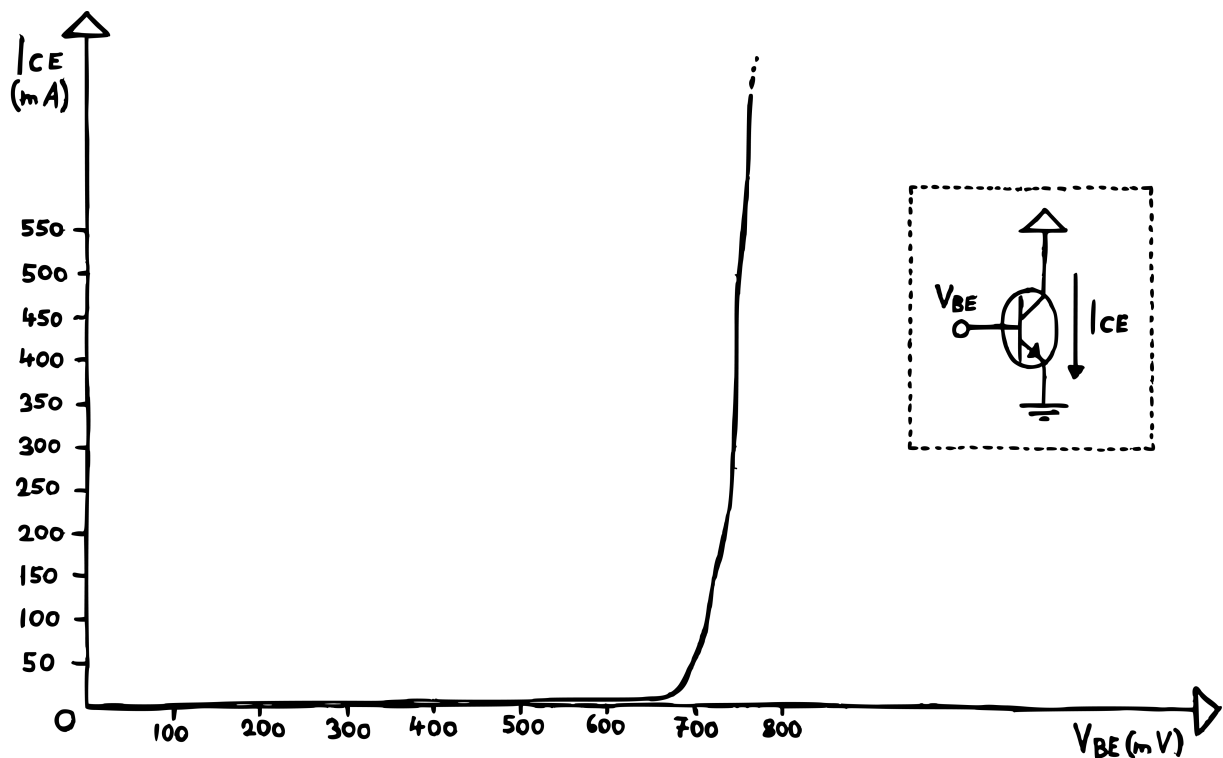

First, the relation between base voltage and collector current is exponential. Second, unlike a resistor, a BJT is not symmetrical – so we can't really reverse the direction of the

¹⁷ Please note that the pinout shown here only applies for the BC series of transistors. Others, like the 2N series, allocate their pins differently.

¹⁸ The voltage is measured between base and emitter. So „a small voltage“ effectively means a small voltage **difference** between base and emitter!

collector current. (At least not without some unwanted side effects.) Third, also unlike a resistor, a BJT is not a linear device. Meaning that a change in collector voltage will not affect the collector current. And fourth, the collector current is affected by the transistor's temperature! The more it heats up, the more current will flow.

Now, for the PNP transistor, all of the above applies, too – except for two little details. Unlike with the NPN, **the PNP transistor decreases its collector current when the voltage at its base increases**¹⁹. So you have to bring the base voltage below the emitter to open the transistor up. Also, that collector current flows out of, not into the collector!

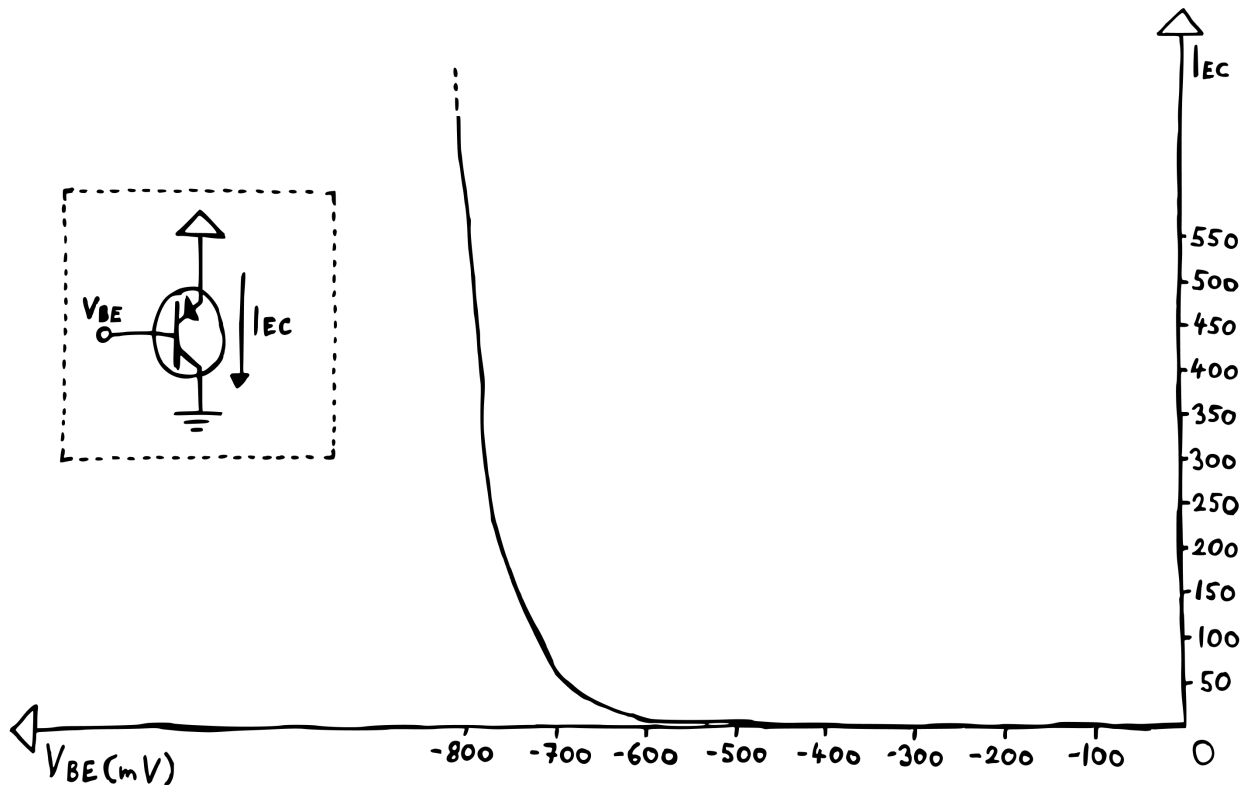

¹⁹ Again, the voltage is measured between base and emitter.

TOOLS APPENDIX

There are two types of tools that will help you tremendously while designing a circuit: multimeters and oscilloscopes. In this appendix, we'll take a quick look at each of these and explore how to use them.

MULTIMETERS

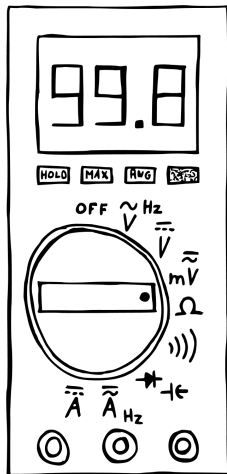

Multimeters come in different shapes and sizes, but the most common type is probably the hand-held, battery powered variant. It can measure a bunch of different things: voltage, current, resistance, continuity. Some have additional capabilities, allowing you to check capacitance, oscillation frequency or the forward voltage drop of a diode.

When shopping for one, you'll probably notice that there are really expensive models boasting about being TRUE RMS multimeters. For our purposes, this is really kind of irrelevant, so don't feel bad about going for a cheap model!

Using a multimeter is actually really straightforward. Simply attach two probes to your device – the one with a black cable traditionally plugs into the middle, while the red one goes into the right connector. Next, find whatever you want to measure and select the corresponding mode setting.

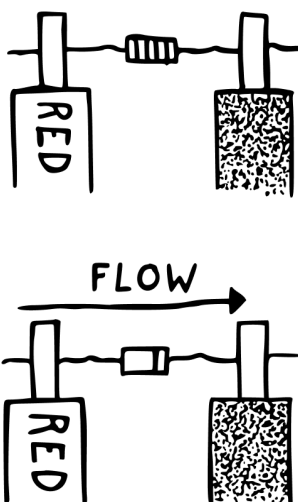

In some cases, it doesn't matter which probe you connect to which component leg or point in your circuit. This is true for testing resistors, non-polarized capacitors (foil/film, ceramic, teflon, glass etc.), continuity²⁰ or AC voltage.

In others, you'll have to be careful about which probe you connect where. For testing the forward voltage drop of a diode, for example, **the multimeter tries to push a current from the red to the black probe**. Here, you'll have to make sure the diode is oriented correctly, so that it doesn't block that current from flowing. For testing a DC voltage, you want to make sure the black probe is connected to ground, while you use the red one to actually take your measurement.

²⁰ Just a fancy word for saying that two points are electrically connected.

OSCILLOSCOPES

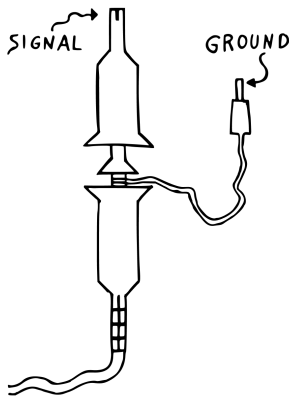
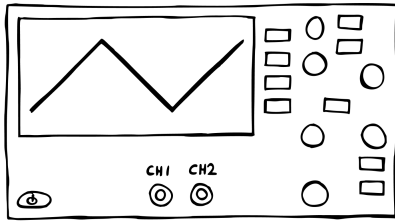

While multimeters are fairly cheap and compact, oscilloscopes are usually somewhat pricey and bulky. **If you're willing to make the investment, they are a huge help with the troubleshooting process, though.** Using one is, again, surprisingly straightforward – if you manage to work your way through the sometimes quite convoluted UI, especially on digital models.

To start using your scope, simply attach a probe to one of the channel inputs. These probes usually have two connectors on the other end: a big one that you operate by pulling the top part back – and a smaller one, which is usually a standard alligator clip. The latter needs to be connected to your circuit's ground rail, while you probe your oscillation with the former. Now what the oscilloscope will do is **monitor the voltage between the two connectors over time and draw it onto the screen as a graph.** Here, the x-axis is showing time, while the y-axis is showing voltage. You can use the device's scaling controls to zoom in on a specific part of your waveform.

Usually, digital oscilloscopes will also tell you a couple useful things about the signal you're currently viewing: minimum/maximum voltage level, oscillation frequency, signal offset. Some even offer a spectrum analyzer, which can be useful to check the frequencies contained in your signal.

BUILD GUIDE

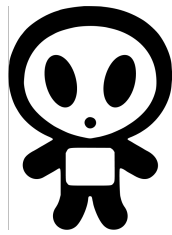

MODULE ASSEMBLY APPENDIX

Before we start building, let's take a look at the complete **mki x es.edu Snare Drum** schematics (see next page) that were used for the final module's design and PCB fabrication. Most components on the production schematics have denominations (a name – like R1, C1, VT1, VD1, etc.) and values next to them. Denominations help identify each component on the PCB, which is particularly useful during **calibration, modification** or **troubleshooting**.

XS1 is the **Accent input** jack socket; it requires +5V gate signal to initiate the accent. **XS2** is the **Tune CV input** jack socket, **XS3** is the **Snappy CV input**, **XS4** is the **Trigger input** jack socket and **XS5** is the **Audio output** jack socket – these are the very same we've already been using on the breadboard for interfacing with other devices. In our designs, we use euro-rack standard 3,5mm jack sockets (part number WQP-PJ301M-12).

XP1 is a standard eurorack power connector. It's a 2x5 male pin header with a key (the black plastic shroud around the pins) to prevent accidental reverse polarity power supply connection. This is necessary because connecting the power incorrectly will permanently damage the module.

XP1 is a standard eurorack **power connector**. It's a 2x5 male pin header with a key (the black plastic shroud around the pins) to prevent accidental reverse polarity power supply connection. This is necessary because connecting the power incorrectly will permanently damage the module.

VD1 and **VD2** are **schottky diodes** that double-secure the reverse polarity power supply protection. Diodes pass current only in one direction. Because the anode of VD1 is connected to +12 V on our power header, it'll only conduct if the connector is plugged in correctly. If a negative voltage is accidentally applied to the anode of VD2, it closes, and no current passes through. The same goes for VD2, which is connected to -12 V. Because schottky diodes have a low forward voltage drop, they are the most efficient choice for applications like this.

Next, we have two **10 Ohm resistors (R9 and R10)** on the + and – 12 V rails, with **decoupling** (or **bypass-**) capacitors **C6 – C9**. These capacitors serve as energy reservoirs that keep the module's internal supply voltages stable in case there are any fluctuations in the power supply of the entire modular system. In combination with R9 and R10, the large 47 microfarad pair (C8 and C9) compensates for low frequency fluctuations, while C6 and C7 filter out radio frequencies, high frequency spikes from a switching power supplies and quick spikes created by other modules. Often another component – a **ferrite bead** – is used instead of a 10 Ohm resistor and there's no clear consensus among electronic designers which works best, but generally for analogue modules that work mostly in the audio frequency range (as opposed to digital ones that use microcontrollers running at 8 MHz frequencies and above), resistors are considered to be superior.

Another advantage of 10 Ohm resistors is that they will act like **slow “fuses”** in case there's an accidental short circuit somewhere on the PCB, or an integrated circuit (IC) is inserted backwards into a DIP socket. The resistor will get hot, begin smoking and finally break the connection. Even though they aren't really fuses, just having them there as fuse substitutes is pretty useful - **you'd rather lose a cent on a destroyed resistor than a few euros on destroyed ICs.**

Capacitors **C2 – C5 and C21, C22** are additional decoupling capacitors. If you inspect the PCB, you'll see that these are placed as close to the power supply pins of the ICs as possible. For well-designed, larger PCBs you will find decoupling capacitors next to each IC. Like the others, their job is to simply compensate for any unwanted noise in the supply rails. If the input voltage drops, then these capacitors will be able to bridge the gap to keep the voltage at the IC stable. And vice-versa - if the voltage increases, then they'll be able to absorb the excess energy trying to flow through to the IC, which again keeps the voltage stable. Typically, 0.1 uF capacitors are used for this purpose.

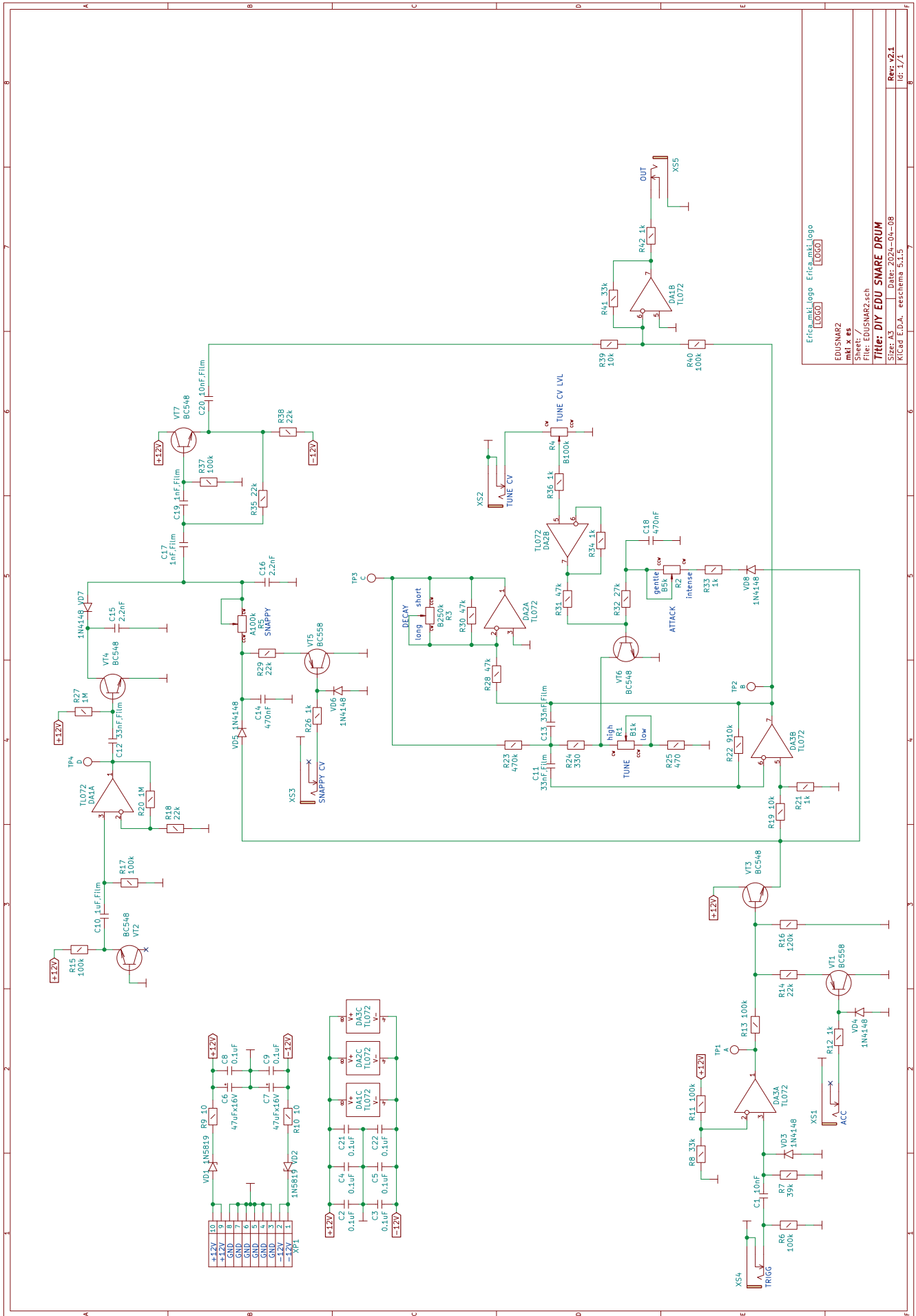

Erica.mki.logo Erica.mki.logo
 EDUSNAR2
 mki x es
 Sheet: /
 File: EDUSNAR2.sch
Title: DIY EDU SNARE DRUM
 Size: A3 Date: 2024-04-08
 KICad E.d.A. eschema 5.1.5

Before you start soldering, we highly recommend printing out the following part placement diagrams with designators and values. Because some of our PCBs are rather densely populated, this will help you to avoid mistakes in the build process.

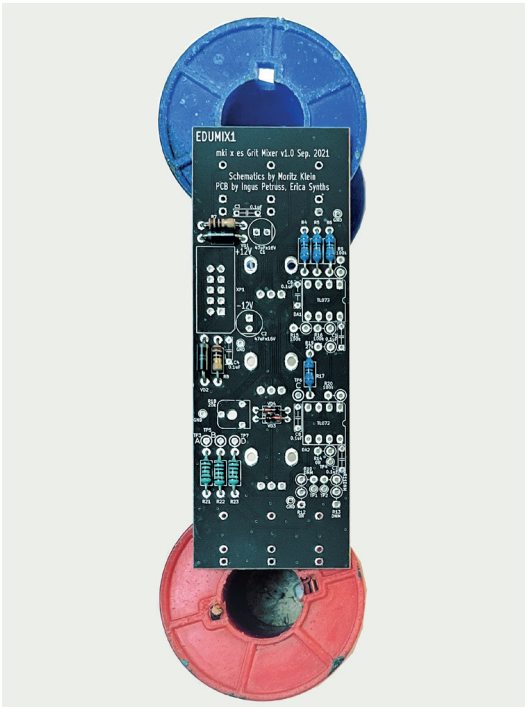

Place the **Snare Drum PCB** in a **PCB holder for soldering** or simply on top of some spacers (I use two empty solder wire coils here).

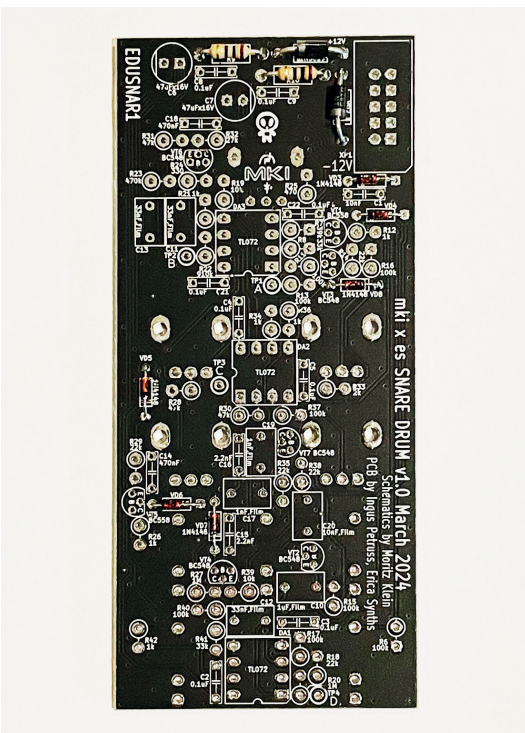

I usually start populating PCBs with lower, horizontally placed components. In this case, these are **10 Ohm resistors, switching diodes** and the **power protection diodes**. Bend the component leads and insert them in the relevant places according to the part placement diagram above. All components on the PCB have both their value and denomination printed onto the silkscreen. If you are not sure about a resistor's value, use a multimeter to double-check. Next, insert the diodes. Remember – **when inserting the diodes, orientation is critical!** A thick white stripe on the PCB indicates the cathode of a diode – match it with the stripe on the component. Flip the PCB over and solder all components. Then, use pliers to cut off the excess leads.

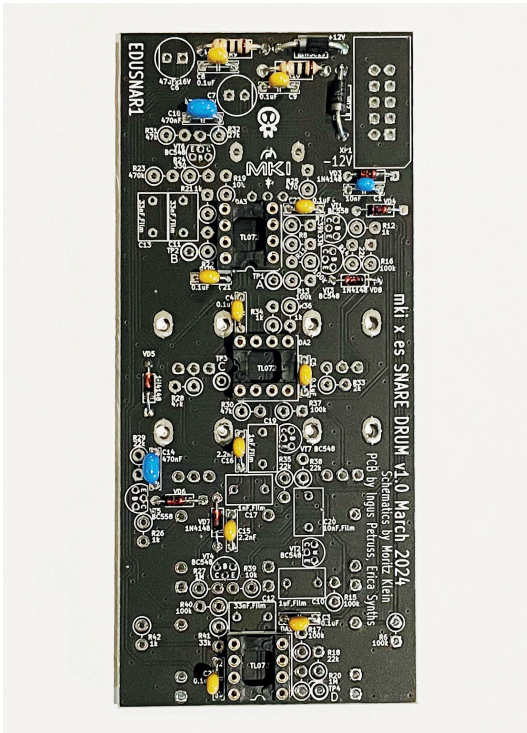

Next, insert the first **DIP socket**, hold it in place and solder one of the pins. Continue with the **next DIP socket**. Make sure the DIP sockets **are oriented correctly** – the notch on the socket should match the notch on the PCB’s silkscreen. Now, turn the PCB around and solder all remaining pins of the DIP sockets. Then insert and solder **the ceramic capacitors**.

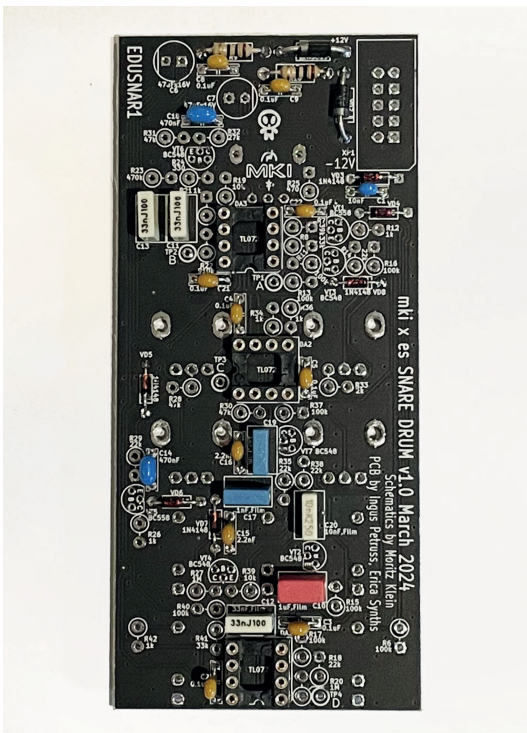

Then proceed with **the film capacitors**. Place the PCB in your PCB holder or on spacers, insert the capacitors and solder them like you did with the resistors & diodes before. Now your PCB should look like this:

In order to save space on the PCB, some of our projects, including the Snare Drum, have vertically placed resistors. The next step is to place & solder those. Bend a resistor's legs so that its body is aligned with both legs and insert it in its designated spot. Then solder the longer lead from the top side of the PCB to secure it in place, turn the PCB around and solder the other lead from the bottom. You can insert several resistors at once. Once done with soldering, use pliers to cut off excess leads.

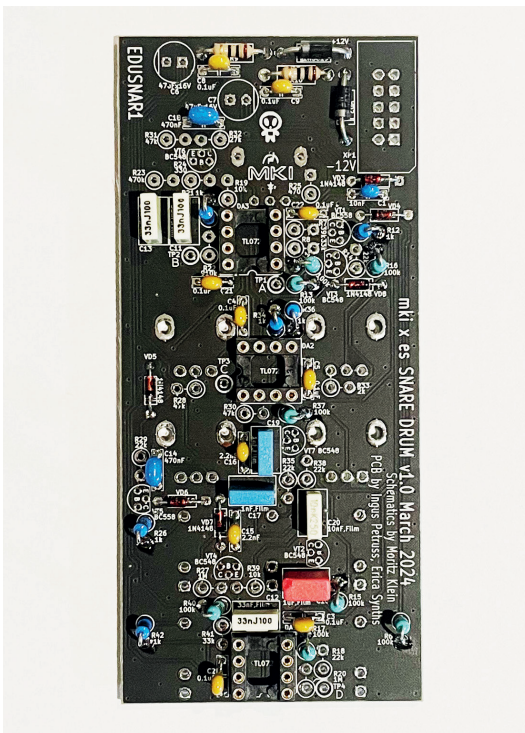
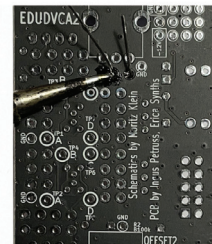
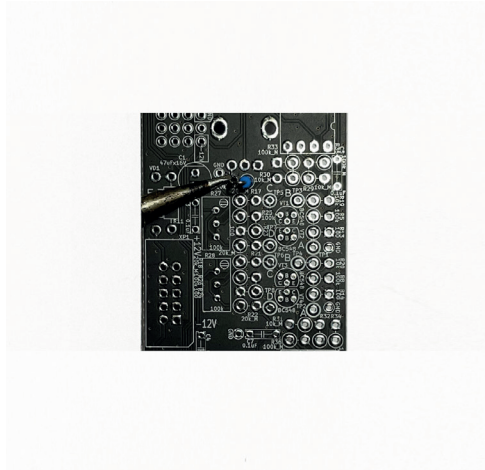

Because the Snare drum features quite few resistors, let's start with **100 k resistors** (light blue on the photo to the left) and **1 k resistors** (dark blue on the photo to the left). When those are installed, the PCB should look like this:

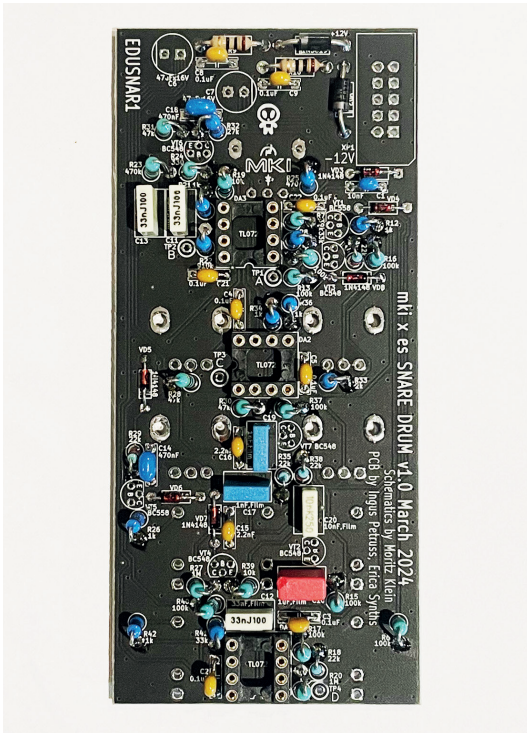

Now, proceed with other vertically placed resistors. If you are not sure about resistor value, use the multimeter to measure resistance of each resistor before soldering them. Once you have completed installing the resistors, your PCB should look like this:

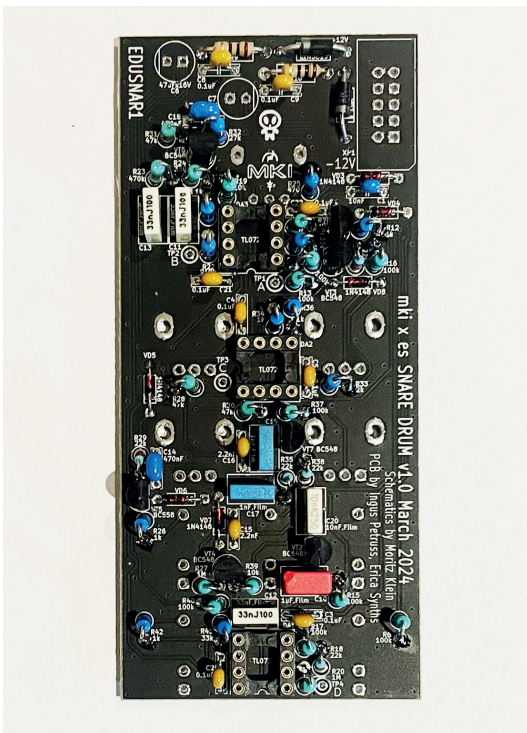

Next, insert and solder **transistors**. There are PNP and NPN transistors in the kit, make sure you install them in correct places and pay attention on the orientation of the transistors – notch on the silkscreen has to match the flat part of the transistor.



Also, **insert & solder the electrolytic capacitors**. Electrolytic capacitors are bipolar, and you need to mind their orientation. The positive lead of each electrolytic capacitor is longer, and there is a minus stripe on the side of the capacitor's body to indicate the negative lead. On our PCBs, the positive pad for the capacitor has a square shape, and the negative lead should go into the pad next to the notch on the silkscreen.

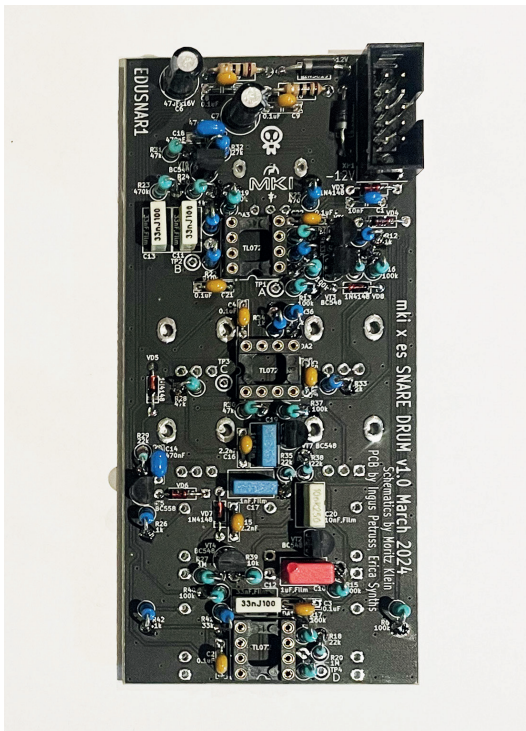

Then complete the component side of the VCF PCB by soldering the **PSU socket**. Make sure the orientation of the socket is as shown in the picture below – the arrow pointing to the first pin is aligned with a notch on the silkscreen. The key on the socket will be facing outwards the PCB. Now your PCB should look like this:

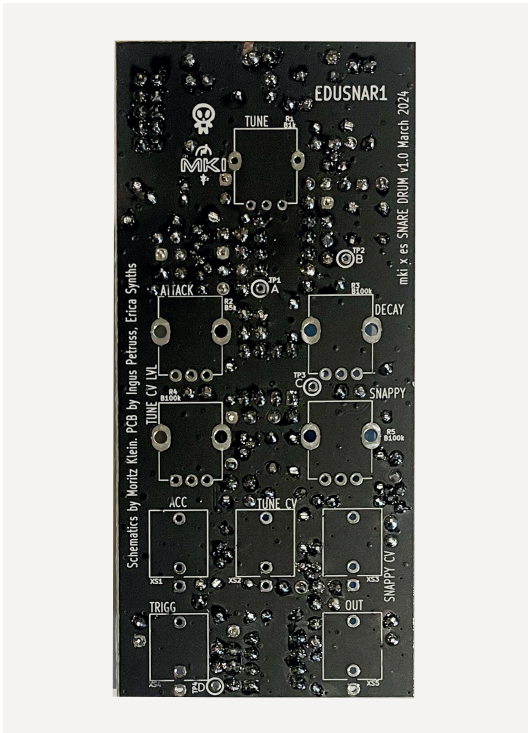

Now, turn the PCB around and inspect your solder joints. **Make sure all components are soldered properly and there are no cold solder joints or accidental shorts.** Clean the PCB to remove extra flux, if necessary.

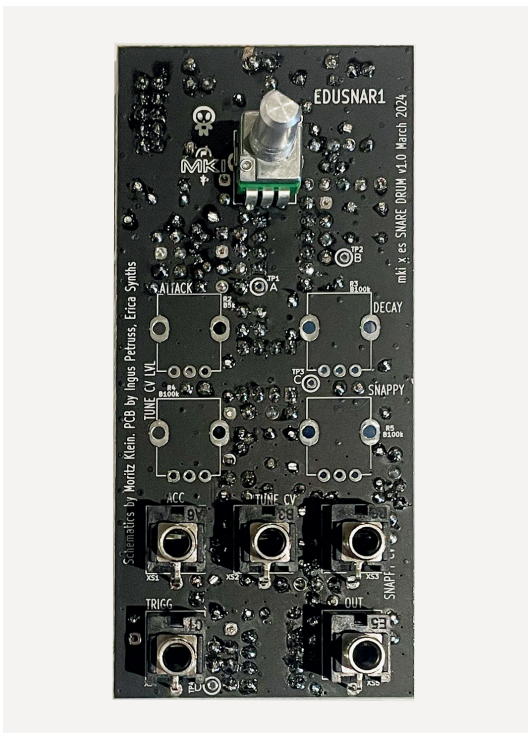

Insert the top potentiometer and jack sockets and solder them.

Insert other potentiometers, but don't solder them yet! Fit the front panel and make sure that the potentiometer shafts are aligned with the holes in the panel – and that they're able to rotate freely. Now, go ahead and solder the potentiometers.

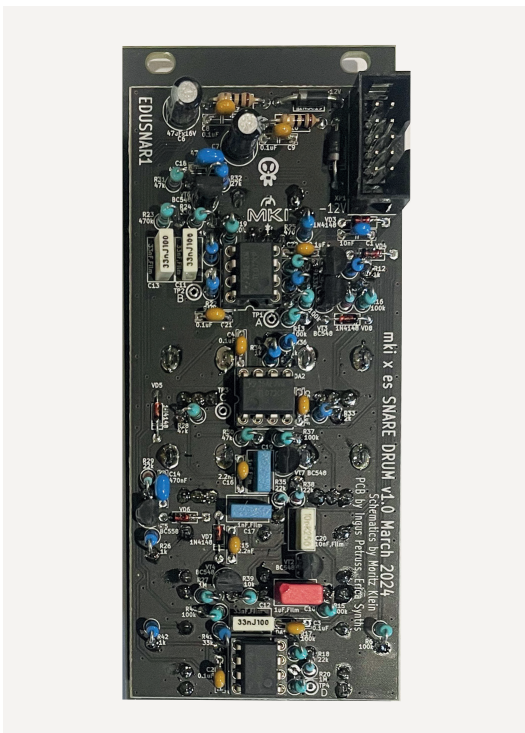
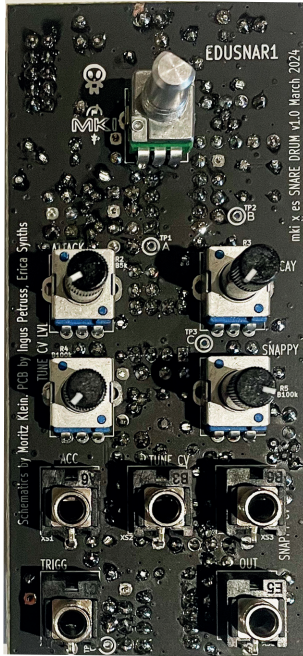

Now, insert the ICs into their respective DIP sockets. Mind the orientation of the ICs – match the notch on each IC with the one on its socket.



Finally fit the Tune potentiometer knob and we are done!

Congratulations! **You have completed the assembly of the mki x es.edu Snare Drum module!** Connect it to your eurorack power supply and switch it on. If there's no "magic smoke", it's a good sign that your build was successful. The module doesn't need any calibration. Patch trigger signal (the gate output of your DIY.EDU Sequencer will be the best choice) to the input of the module and connect the output of the module to a mixer. You should hear the kick drum sound. Turn gates on the sequencer on and off in order to achieve a desired kick drum pattern and tweak some knobs on the module to observe change of the sound.

Enjoy!

SOLDERING APPENDIX

If you've never soldered before – or if your skills have become rusty – it's probably wise to check out some **THT** (through-hole technology) **soldering tutorials on YouTube**. The main thing you have to remember while soldering is that melted solder will flow towards higher temperature areas. So you need to make sure you apply equal heat to the component you are soldering and the solder pad on the PCB. The pad will typically absorb more heat (especially ground-connected pads which have more thermal mass), so keep your soldering iron closer to the pad on the PCB. It's critically important to dial in the right temperature on your soldering station. I found that about 320 °C is the optimal temperature for most of parts, while for larger elements like potentiometers and sockets, you may want to increase that temperature to **370 °C**.

Here's the recommended soldering sequence:

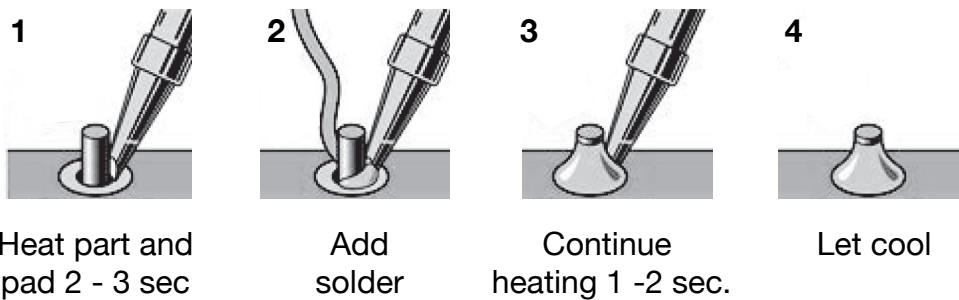

After you have completed soldering, inspect the solder joint:

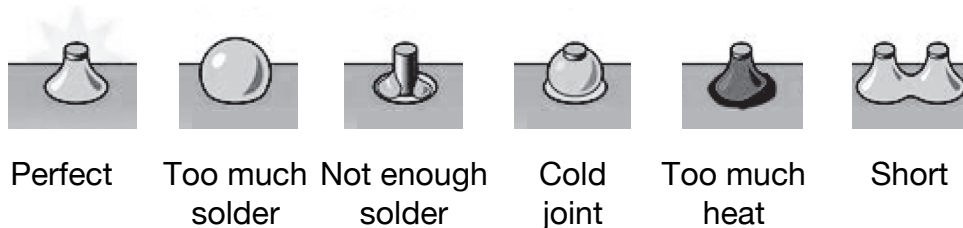

DIY electronics is a great (and quite addictive) hobby, therefore we highly recommend you invest in good tools. In order to really enjoy soldering, you'll need:

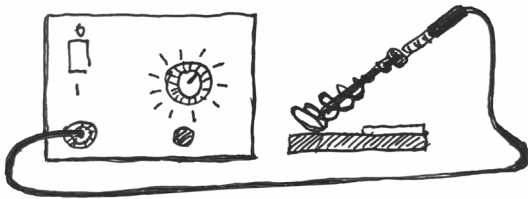

A decent soldering station. Top-of-the-line soldering stations (brands like Weller) will cost 200€ and above, but cheaper alternatives around 50€ are often good enough. Make sure your soldering station of choice comes with multiple differently-sized soldering iron tips. The most useful ones for DIY electronics are flat, 2mm wide tips.

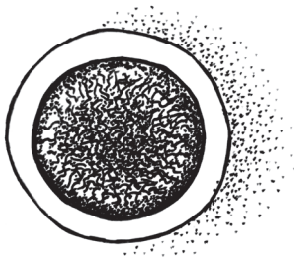

When heated up, the tips of soldering irons tend to oxidize. As a result, solder won't stick to them, so you'll need to clean your tip frequently. Most soldering stations come with a **damp sponge for cleaning the iron tips** – but there are also professional solder tip cleaners with **golden curls** (not really gold, so not as expensive as it sounds). These work much better because they do not cool down the iron.



Solder wire with flux. I find 0,7mm solder wire works best for DIY projects.

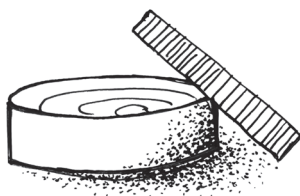

Some **soldering flux** paste or pen will be useful as well.



Cutting pliers. Use them to cut off excess component leads after soldering.

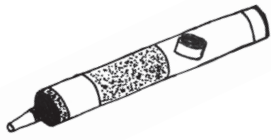

A solder suction pump. No matter how refined your soldering skills are, you will make mistakes. So when you'll inevitably need to de-solder components, you will also need to remove any remaining solder from the solder pads in order to insert new components.

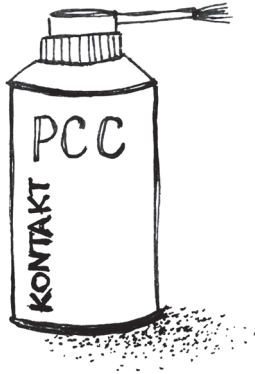

Once you have finished soldering your PCB, it's recommended to remove excess flux from the solder joints. **A PCB cleaner** is the best way to go.

All of these tools can be found on major electronic components retailer websites, like Mouser, Farnell and at your local electronics shops. As you work your way towards more and more advanced projects, you'll need to expand your skillset and your tool belt – but the gratification will be much greater.

“I just love the hypnosis of a single bass drum.”

– Jon Hopkins